



INSTRUCTIONS

-J03511

REV. 2005-03-16

DYNA SHIFT LINKAGES

GENERAL

Kit Number

Table 1. Kit Number and Style

Kit Number	Style
33761-06	Slotted Bar and Shield
33815-06	Round
33818-06	Twisted
33799-06	"H-D"
33838-06	Flame
33865-06	"Dyna"
34848-06	Skull

Models

These kits fit 2006 and later Dynas with Forward Controls.

Kit Contents

See Figure 1 and Table 2.

INSTALLATION

NOTE

All numbers referenced in steps below refer to Figure 1 and Service Manual.

1. Remove existing shifter rod.
2. Adjust new shifter rod in kit to match the length of the existing shifter rod removed by loosening locknuts (3), adjusting the length of the rod, then retightening locknuts to 20-24 ft-lbs (27-32 Nm).
3. Place spacer (7) and cover (1) over the shifter rod lever.
4. Apply Loctite® 242 (blue) to threads of one of the capscrews (5) and thread cap screw through the rear of the shifter rod and into the shifter rod lever. Tighten cap screw (5) to 13-16 ft-lbs (18-22 Nm).
5. Place the rod end on the outside of the shifter lever, then apply Loctite® 242 (blue) to the threads of the other cap screw (5) and attach the front of the shifter rod (6) to the shifter lever with cap screw (5) and acorn nut (4) in order shown in illustration (acorn nut facing out). Tighten acorn nut (4) to 13-16 ft-lbs (18-22 Nm).

SERVICE PARTS

is00292

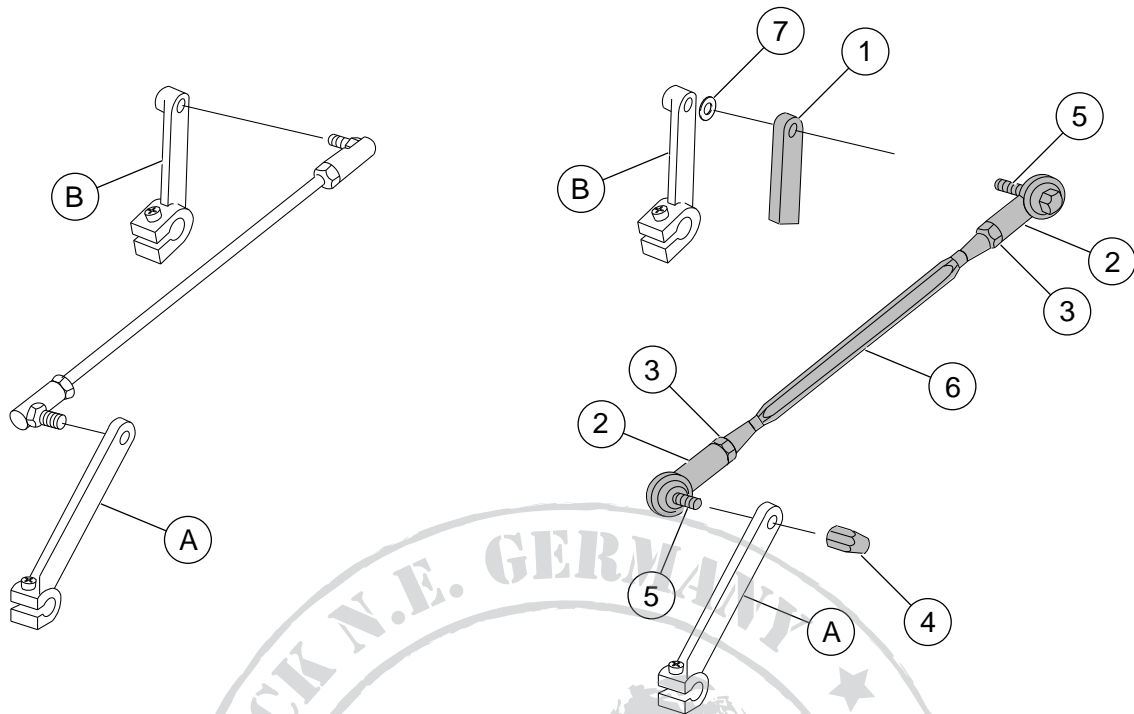

Figure 1. Service Parts: Dyna Shift Linkages

Table 2. Service Parts: Dyna Shift Linkages

Item	Description (Quantity)	Part Number
Items included in kits (shown shaded on illustration)		
1	Shifter rod lever cover	33890-99A
2	Self-aligning rod ends (2)	33888-99
3	Locknuts (2)	33889-99
4	Acorn nut	7904
5	Capscrews (2)	4192
6	Shifter rod	Not Sold Separately
7	Spacer	5826
Items mentioned in text, but not included in kit.		
A	Original equipment shift lever	
B	Original equipment shift rod lever (on transmission)	