



INSTRUCTIONS

-J03481

REV. 08-31-04

Kit Number 33100-03A

6 SPEED TRANSMISSION SUPER KIT

General

This kit fits 1990-1999 Softail and 1991-2000 Dyna model motorcycles. Requires separate purchase of cable Sidecover Release Kit or Hydraulic Sidecover Release Kit. Hydraulic Side Cover Release Kit is not compatible with 1990-1999 Softail or 1991-1998 Dyna models. See retail catalog for parts numbers. Refer to Instructions included in Sidecover Release Kits to complete installation of Screamin' Eagle 6-Speed Transmission or Gearset Kits.

In addition to the above kits, the 2005 Touring Model Service Manual (Part Number 99483-05) and Main Drive Gear Remover & Installer Kit (Part Number 35316-B) must be purchased. See your Harley-Davidson dealer.

For a list of items contained in this kit, see the Service Parts illustration.

GEAR	STOCK 5-SPEED	SE 6-SPEED
First	3.210	3.210
Second	2.209	2.209
Third	1.572	1.572
Fourth	1.226	1.226
Fifth	1.000	1.000
Sixth	N/A	0.885

WARNING

The rider's safety depends upon the correct installation of this kit. If the procedure is not within your capabilities or you do not have the correct tools, have your Harley-Davidson dealer perform the installation. Improper installation of this kit could result in death or serious injury. (00308a)

NOTE

A Service Manual for your model motorcycle is available at any Harley-Davidson Dealer.

Removal

NOTE

Leave the transmission case in the frame unless the case itself requires replacement. For ease of illustration, photographs show the case removed.

1. Using the appropriate service manual, proceed as follows:
 - a. Drain the primary chaincase and transmission lubricants.

WARNING

To prevent accidental vehicle start-up, which could cause death or serious injury, disconnect negative (-) battery cable before proceeding. (00048a)

- b. Unthread bolt and remove battery negative cable (black) from battery negative (-) terminal.

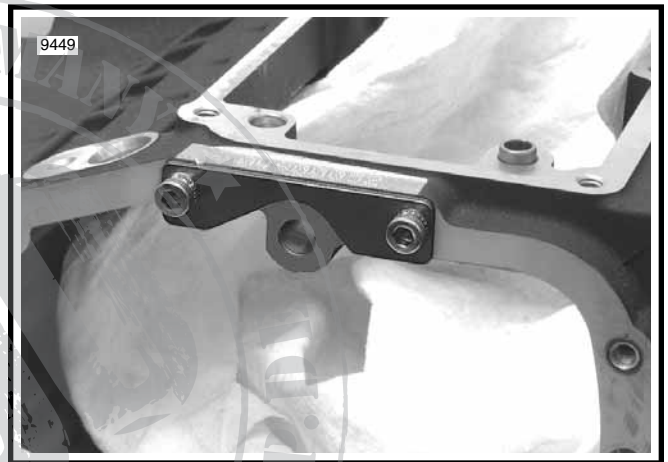

Figure 1. Install Drill Plate to Transmission Case

- c. Remove the primary chaincase cover. Remove the clutch assembly, primary chain, and compensating sprocket components. Remove the starter jackshaft assembly.
- d. Remove the exhaust system as necessary to gain complete access to the transmission side door.
- e. Remove the starter. Remove primary chaincase.
- f. Remove the clutch release cover. Remove the clutch cable from the clutch release cover.
- g. Remove the vehicle speed sensor.
- h. Remove the transmission top cover.
- i. Remove neutral switch from transmission top cover.
- j. Remove the drum support blocks and shift drum. Remove the drum support block dowels from deck of transmission case.
- k. Remove the fork shaft and shifter fork assemblies.
- l. Remove the bearing inner race from the transmission mainshaft.
- m. Remove the transmission side door and the mainshaft/countershaft assembly.

NOTE

The front dowel pin may be stuck in the side door after removal. If this occurs, remove the dowel pin from the side door and install it back into the transmission case.

- n. Remove the shifter shaft assembly and shifter seal.
- o. Remove the main drive gear and bearing.

NOTE

Detailed instructions on removing the main drive gear and bearing can be found in the 2005 Touring Model Service Manual (Part No. 99483-05), **Section 7.7 MAIN DRIVE GEAR/BEARING.**

- p. Remove the countershaft needle bearing.
2. Using masking tape, cover all the side door flange holes with the exception of the top three.

NOTE

While the two threaded holes at the top of the flange are used for mounting of the drill plate, the fork shaft hole (center thru hole) is used as the pilot for the drill bits.

3. From inside the transmission case, tape over all bores as follows:
 - Vehicle speed sensor and mounting screw bores
 - Transmission top cover and shift drum support block screw bores
 - Transmission drain hole bore
 - Main drive gear bearing bore
 - Countershaft needle bearing bore
 - Fork shaft bore
 - Shifter shaft bore

CAUTION

Be sure drill plate is properly oriented. Improper orientation will result in damage that requires replacement of the transmission case.

4. Obtain the drill plate (Part No. 35155-03) provided in kit and fasten to top of side door flange using old and new vehicle speed sensor mounting screws.
5. Spread one or two clean shop cloths inside the transmission case to catch the metal shavings and debris.
6. Starting with a 3/8 inch drill bit, alternately use progressively larger bits to enlarge the fork shaft hole. Finish the drilling operation with a 3/4 inch drill bit.
7. Remove all remaining material up to the edge of the drill plate with a die grinder or similar tool. Remove the drill plate.
8. Using emery cloth, steel wool, or a fine tooth file, remove any burrs or ridges that may exist from the drilling or cutting operation.
 - q. If applicable, remove sleeve from shifter shaft bore. Proceed as follows:
 - a. Obtain shifter shaft sleeve remover/installer tool provided in kit (Part No. 35156-03).
 - b. From the outside of the transmission case (left side), insert smaller diameter end of remover into shifter shaft sleeve (knurled side out). Using a 30 ounce brass hammer (minimum), tap the end of the

remover with light blows until the shifter shaft sleeve is free of the transmission case.

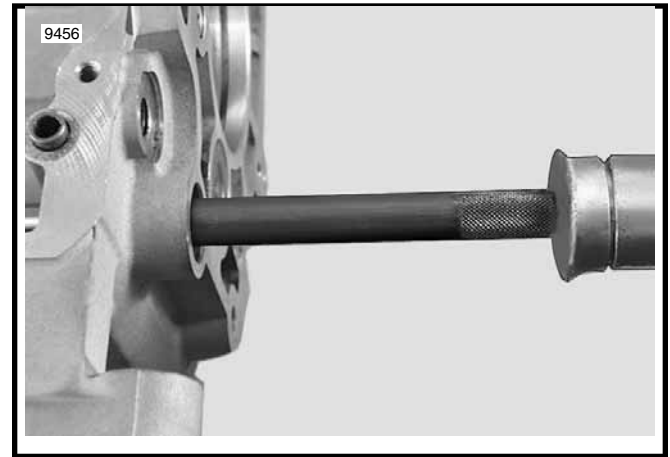

Figure 2. Remove Shifter Shaft Sleeve

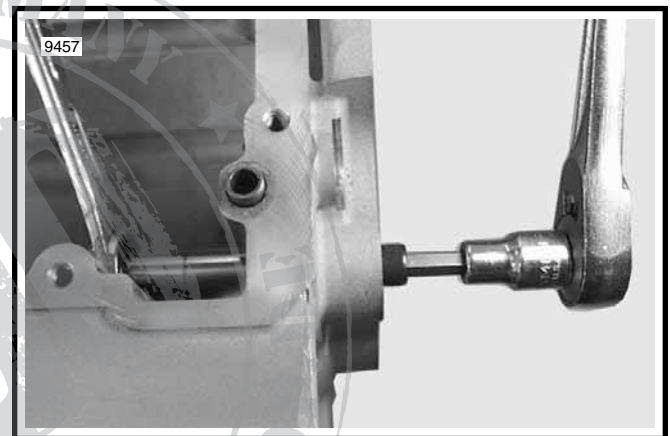

Figure 3. Install Shifter Shaft Sleeve

- c. Carefully remove any burrs from in or around the sleeve bore.

CAUTION

Abrasive particles can damage machined surfaces and result in premature failure.

9. Carefully pull out shop cloths from inside the transmission case. Exercise care to keep any debris captured by the cloths from falling into the transmission case.
10. Place drain pan beneath transmission case and remove tape from drain hole. Thoroughly flush the transmission case with a non-volatile cleaning solution or solvent to remove any metal shavings, dust or debris that might remain. For best results, use a squirt bottle to direct a stream of solvent through the transmission top cover opening. Repeat procedure as necessary draining excess solvent through the drain hole.
11. Using low pressure compressed air, thoroughly blow out all solvent.
12. Using a clean lightly oiled cloth, thoroughly wipe the inside of the transmission case. Repeat this step with a new cloth until the cloth comes out clean.

13. Carefully inspect the transmission case for any metal shavings or debris. Repeat steps 11 through 13 if any debris is found.
14. Remove the masking tape to uncover remaining holes and bores.
15. Thoroughly inspect each bore for any metal shavings, dust or debris. Alternately direct compressed air into each bore to be certain that it is clean and dry.

Installation

NOTE

Prelube all bearings and shafts with clean transmission lubricant or SYN-3 (depending on your choice of lubricate) prior to installation.

1. Using the appropriate service manual, proceed as follows:
 - a. Install the countershaft needle bearing.
 - b. Install the main drive gear and bearing.

NOTE

Detailed instructions on installing the main drive gear and bearing can be found in the 2005 Touring Model Service Manual (Part No. 99483-05), Section 7.7 MAIN DRIVE GEAR/BEARING.

2. Install sleeve into shifter shaft bore. Proceed as follows:
 - a. Obtain shifter shaft sleeve remover/installer tool provided in kit (Part No. 35156-03).
 - b. Place **new** sleeve over installer. Place thrust washer, thrust bearing and then the second thrust washer onto installer screw.
 - c. Apply a very thin film of HD 20W50 engine oil to OD of new sleeve, ID and OD installer threads and ID of sleeve bore. Also apply a very thin film of HD 20W50 engine oil to the thrust bearing and thrust washers.
 - d. From inside the transmission case, hold the sleeve and installer against the sleeve bore. From outside the transmission case, thread the installer screw assembly into the installer keeping the sleeve properly aligned.
 - e. Using a 3/4 inch box wrench, hold the hex on the installer inside the transmission case.
 - f. Using a 1/4 inch allen wrench or socket, tighten the installer screw until the sleeve stops against the first thrust washer.
 - g. Remove the tool from the transmission case.
 - h. Apply a very thin film of HD 20W50 engine oil to sleeve ID and **new** shifter shaft. From outside the transmission case, slide shaft through sleeve and then rotate. Shaft must rotate freely a full 360 degrees. Remove shifter shaft assembly.
 - i. Install shifter shaft assembly from inside the transmission case. Cover splines of shaft with tape to protect seal. Install the new shifter shaft seal. Remove tape and install new shifter seal washer and new retaining ring.

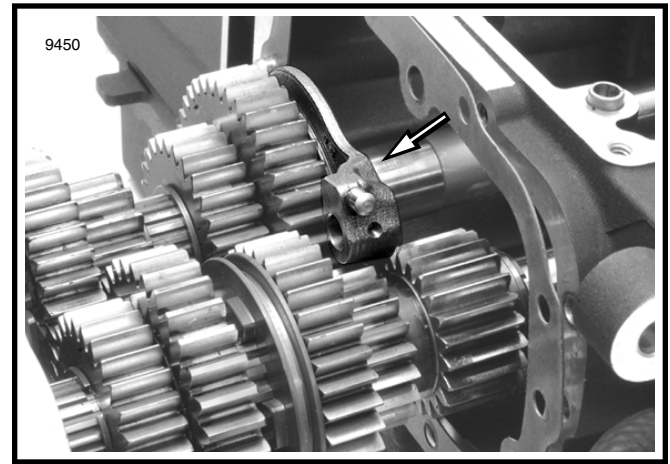

Figure 4. Install 5-6 Shifter Fork Onto Shift Ring

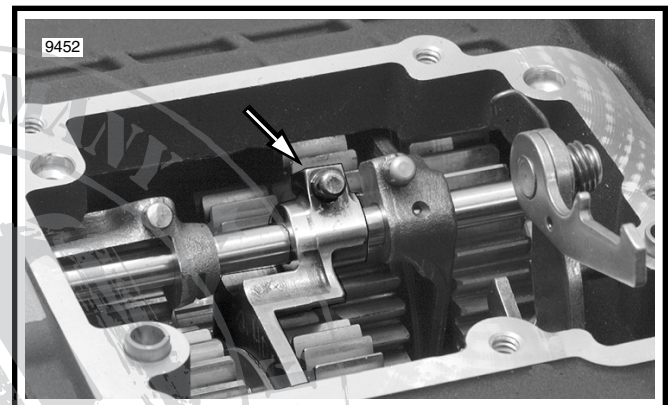

Figure 6. Install 1-2 Shifter Fork Onto Shift Ring

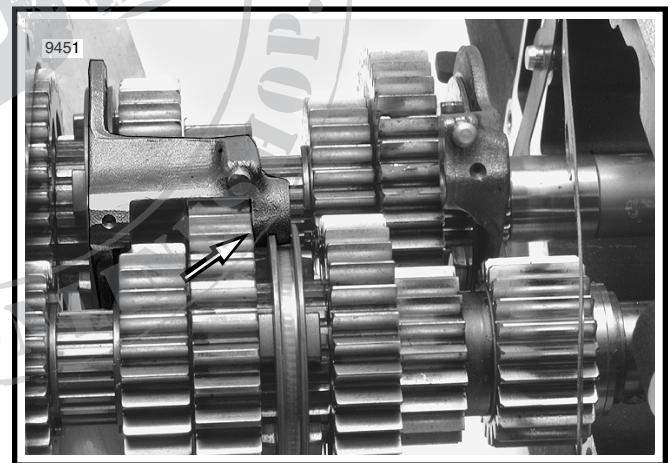

Figure 5. Install 3-4 Shifter Fork Onto Shift Ring

3. Install the transmission side door and mainshaft/countershaft assembly as follows:

CAUTION

Leave the shrink wrap on the mainshaft until side door installation is complete. Installation of the side door with the shrink wrap removed may result in damage to the main drive gear seal.

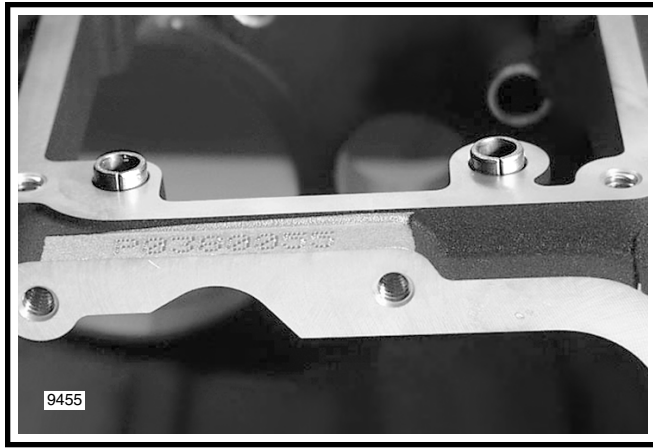

Figure 7. Orient Shift Drum Support Block Dowels

CAUTION

Be sure to remove the plastic cap and cable strap from the mainshaft before side door installation. Blow away any styrofoam bits or other packaging material that might be clinging to gears or splines.

- a. Hang **new** side door gasket on dowels in side door flange of transmission case.
- b. Start side door and mainshaft/countershaft assembly into transmission case, but stop so that all gears remain on the outboard side.
- c. Note that there are three shifter forks, each of which are stamped for easy identification. Set aside the 5-6 shifter fork, the 3-4 shifter fork and the 1-2 shifter fork in that order.
- d. Install the 5-6 shifter fork into the shift ring outboard of the 6th gear on the mainshaft (shift ring closest to the main drive gear).
- e. Install the 3-4 shifter fork into the shift ring between the 4th and 3rd gears on the mainshaft (shift ring closest to the side door). Be sure the dogs on the shift ring are engaged with mainshaft 3rd gear and then rotate shifter fork toward the countershaft until the slot in the fork engages the edge of the shift ring between 1st and 2nd gears on the countershaft. This engagement is necessary to obtain the proper clearance for side door installation.
- f. Slide side door assembly further into transmission case stopping about one inch before mating flanges make contact.
- g. Start fork shaft through hole in side door.
- h. Through the transmission top cover opening, install the 1-2 shifter fork into the shift ring between 1st and 2nd gears on the countershaft. For proper clearance, be sure the dogs on the 3-4 shift ring (closest to side door on the mainshaft) are fully engaged with mainshaft 4th gear.
- i. Slide fork shaft through holes in shifter forks and then fully install side door. Be sure that end of fork shaft engages plugged hole on left side of transmission case.

- j. Install fork shaft set screw in transmission side door. Tighten screw until the shaft has minimum endplay, but still rotates freely.
 - k. Install **new** side door plug into side door. FXST models use the magnetic style drain plug, while FXD uses the non-magnetic plug.
 - l. Remove shrink wrap from the mainshaft.
4. Using the appropriate service manual, proceed as follows:
 - a. Install four **new** drum support block dowels in deck of transmission case. Orient the dowels so that the split line is aligned left to right.
 - b. Install **new** drum support blocks with **new** shift drum.
 - c. Rotating output shaft by hand, shift through all six gears to verify proper operation. Input shaft may need to be rocked back and forth to get all gears to shift.
 - d. Install the mainshaft oil seal, quad seal, spacer sleeve/sprocket spacer, sprocket, and sprocket nut.

NOTE

1990- mid 1994 models use a taller sprocket spacer Part Number 33334-85 and mainshaft oil seal Part Number 12050. These parts are not included with the kit and will need to be purchased separately. If a newer model sprocket is used 40250-94C, the mainshaft oil seal and the sprocket spacer in the kit may be used. The 2005 Touring models Service Manual (Part Number 99483-05) includes detailed instructions on installing the mainshaft oil seal, quad seal, spacer sleeve, sprocket and sprocket nut in **Section 7.7, MAIN DRIVE GEAR/BEARING.**

- e. Install the **new** bearing inner race onto the transmission mainshaft.
5. On 1999 and 2000 Dyna models only, the transmission top cover must be modified for proper clearance with the shifter assembly. Proceed as follows:

NOTE

For 1990-1999 Softail and 1991-1998 Dyna model motorcycles, proceed directly to step 6.

- a. Place the **new** gasket supplied in kit (Part No. 34917-99B) on the transmission top cover flange. Hold the gasket in place by dropping the four transmission top cover screws through the gasket and top cover holes.
- b. With a suitable marker, highlight the exposed portion of the flange. The area where material is to be removed is approximately 0.60 inches wide by 1.80 inches deep. Remove the top cover screws and gasket.
- c. With a die grinder or similar tool, remove the casting rib until it is the same height as the adjacent surface area.
- d. Use low pressure compressed air to blow away any dust or debris. Verify that all holes are clean and open.

- e. Start two screws to **loosely** install the transmission top cover and gasket to the transmission case, but be sure that no more than two threads of each screw are engaged.

CAUTION

Over tightening the transmission top cover can cause the shifter assembly to break through the casting rib if an insufficient amount of material was removed. Damage to the top cover and/or shifter assembly requires part replacement.

- f. While watching to see if the top cover moves forward, shift the transmission into first gear firmly holding the shift lever down.



Figure 8. Modified Transmission Top Cover

- g. If there is no forward movement of the top cover, then the modification is complete. On the other hand, if any forward movement is observed, then more of the casting rib must be removed; repeat steps 5(a) thru 5(g) as necessary.
6. Using the appropriate service manual, proceed as follows:
 - a. Install the transmission top cover with **new** gasket.

NOTE

The transmission shifter must be in the NEUTRAL position when installing the switch to allow the bottom ball on the switch to engage the ramp on the shifter cam.

- b. Install **new** neutral switch into the transmission top cover. For 1998 or later models or if you are replacing your stock top cover with a 1998 or later model top cover, DO NOT remove the o-ring. For 1990-1997 model years, remove the o-ring from the neutral switch and install the aluminum washer Part Number 6288 with the chamfer side of washer away from the switch body followed by the nylon washer Part Number 33043-80 on the neutral switch. These parts are included in the bag with your neutral

switch. Install the neutral switch into top cover and torque to 120-180 **in-lbs** (13.6-20.3 Nm).

- c. Install connectors on neutral switch studs. For 1990 thru 1997 model years, refer to the wiring diagram at the back of the service manual. The wiring harness for these years has a single cap connector (Part Number 9905) connected to the neutral switch. Replace the single cap connector as follows:
 - Cut single cap connector off stock wire.
 - Connect the supplied TAN wire (Part No. 72405-98TN) to the cut wire with the supplied connector (Part No. 70585-93) and attach onto either pole of the neutral switch.
 - Attach the other supplied new BLACK wire (Part No. 72405-98BK) to the remaining pole.
 - Attach the supplied eyelet (Part No. 72241-94A) to the other end of the new BLACK wire and attach to a convenient grounding location.
- d. Install primary chaincase.
- e. Install the starter.
- f. Install the exhaust system.
- g. Install the starter jackshaft assembly. Install the clutch assembly, primary chain, and compensating sprocket components. Install the primary chaincase cover.
- h. Install drain plugs and fill the primary chaincase with the recommended lubricants.
7. Install plate with gasket over vehicle speed sensor bore in transmission case using existing hardware, if applicable.
8. Install vehicle speed sensor at top of transmission side door using **new** o-ring.

NOTE

If the vehicle is not equipped with a vehicle speed sensor, install the vehicle speed sensor plug, o-ring and screw.

9. Install side cover.

For **Cable Actuated Clutch**: Follow the instructions in the SE 6-Speed Cable Clutch Side Cover and Release Pushrod Kit (Part Number 38752-04).

For **Hydraulic Clutch**: Follow the instructions in the Hydraulic Cable Side Cover and Release Pushrod Kit (Part Number 38753-04), and in the Hydraulic Clutch Kit (Part Number 45033-03, Black or 45383-03, Chrome).
10. Install battery negative cable (black) to battery negative (-) terminal.

TRANSMISSION SERVICE

11. Replace the transmission lubricant after the first 500 miles. Thereafter, refer to the Service Manual and change the lubricant at the recommended service intervals.



6 Speed Transmission Super Kit

i06780

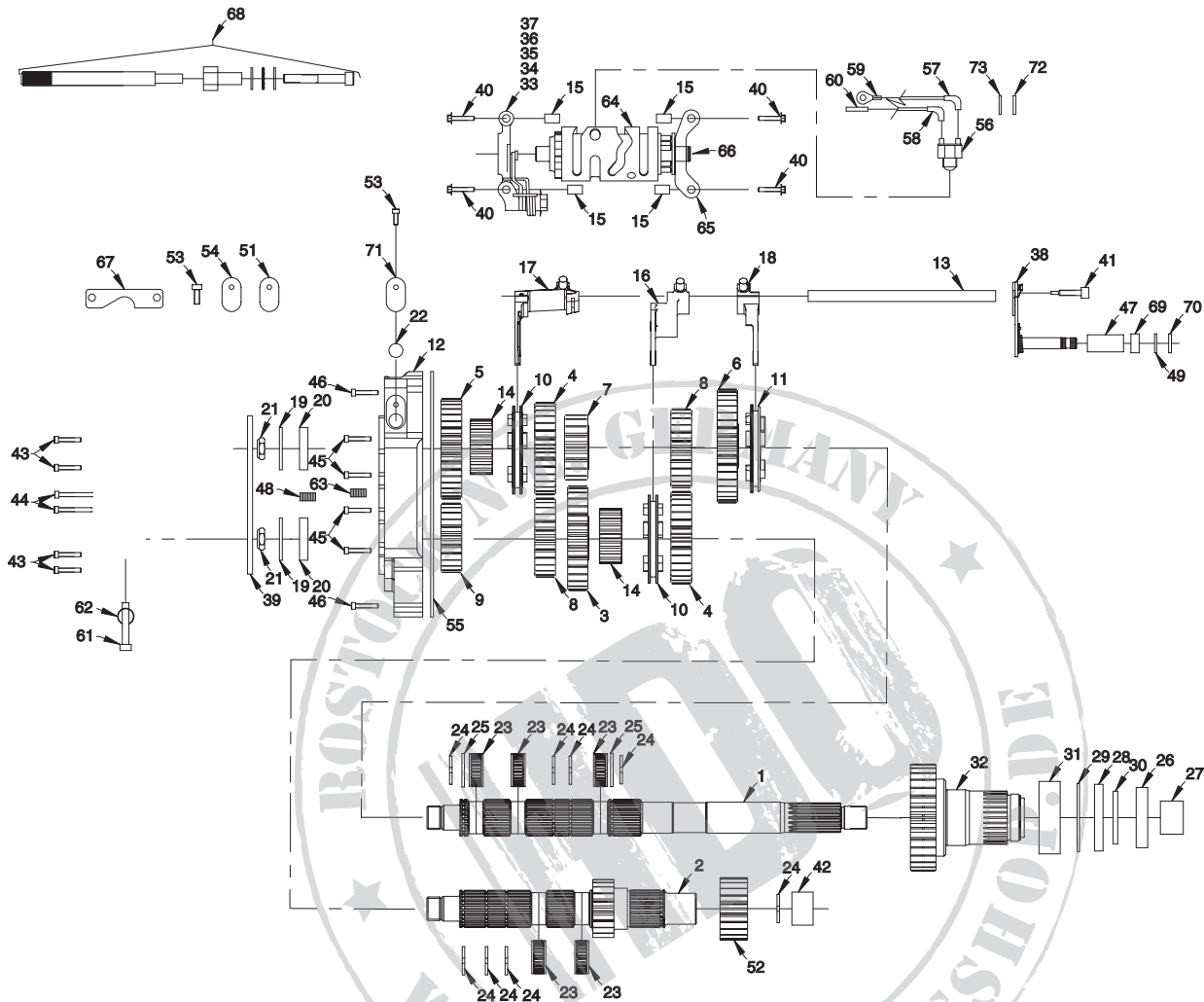

- 1. Mainshaft
- 2. Countershaft
- 3. Countershaft 1st Gear
- 4. Mainshaft 3rd Gear/
Countershaft 2nd Gear (2)
- 5. Mainshaft 4th Gear
- 6. Mainshaft 6th Gear
- 7. Mainshaft 1st Gear
- 8. Countershaft 3rd Gear/
Mainshaft 2nd Gear (2)
- 9. Countershaft 4th Gear
- 10. Shift Ring, 1-2, 3-4 (2)
- 11. Shift Ring, 5-6
- 12. Chrome Side Door w/Ear
- 13. Shifter Fork Shaft
- 14. Splined Sleeve (2)
- 15. Pillow Block Dowel (4)
- 16. Shifter Fork, 1-2
- 17. Shifter Fork, 3-4
- 18. Shifter Fork, 5-6
- 19. Door Retaining Ring (2)
- 20. Trap Door Bearing (2)
- 21. Mainshaft/Countershaft
Locknut (2)
- 22. Speedo Sensor O-Ring (2)
- 23. Split Cage Bearing (5)
- 24. Mainshaft/Countershaft
Retaining Ring (8)
- 25. Mainshaft Thrust Washer (2)

- 26. Sprocket Spacer
- 27. Mainshaft Race
- 28. Main Case Seal
- 29. Case Bearing Retaining Ring
- 30. Quad Seal
- 31. Main Case Bearing
- 32. Main Shaft, 5th Gear
- 33. Right Pillow Block
- 34. Detent Arm Screw
- 35. Detent Sleeve
- 36. Detent Follower
- 37. Detent Arm Spring
- 38. Shifter Shaft Assembly
- 39. Side Cover Gasket
- 40. Pillow Block Screw (4)
- 41. Shifter Centering Screw
- 42. Countershaft Bearing
- 43. Clutch Release Cover
Lower Screw (4)
- 44. Clutch Release Cover
Upper Screw (2)
- 45. Lower Trap Door Screw (4)
- 46. Upper Trap Door Screw (2)
- 47. Shifter Shaft Sleeve
- 48. Side Door Plug, Magnetic
- 49. Shifter Seal Washer

- 50. Shifter Fork Shaft Screw
- 51. Sensor Plate Gasket
- 52. Countershaft 5th Gear
- 53. Speedo Sensor Plate Screw (2)
- 54. Sensor Plate
- 55. Trap Door Gasket
- 56. Neutral Switch
- 57. Wire Assembly (Black)
- 58. Wire Assembly (Tan)
- 59. 1/4 Inch Ring Terminal (18-20 ga.)
- 60. Connector (18-20 ga.)
- 61. Chrome Dipstick
- 62. Dipstick O-Ring
(1ea. FXST, 2ea. FXD)
- 63. Trap Door Plug-Non Magnetic
(Drain for 91-00 FXD Only)
- 64. Shift Drum Assembly
- 65. Left Pillow Block
- 66. Shift Drum Retainer
- 67. Case Modification Tool
- 68. Tool (Remove/Install Shifter Shaft
Sleeve)
- 69. Shifter Seal
- 70. Shifter retaining Ring
- 71. Speedo Sensor Plug

- 72. Nylon Washer
- 73. Washer

Items Not Shown:

- Lid Gasket, FXST
- Lid Gasket, FXD 1991-98
- Lid Gasket, FXD 1999-00
- Fill Spout Gasket, FXD 1991-98
- Oil Fill Spout Lower O-Ring, FXD
- Oil Stick O-Ring, FXD (2)



6 Speed Transmission Super Kit

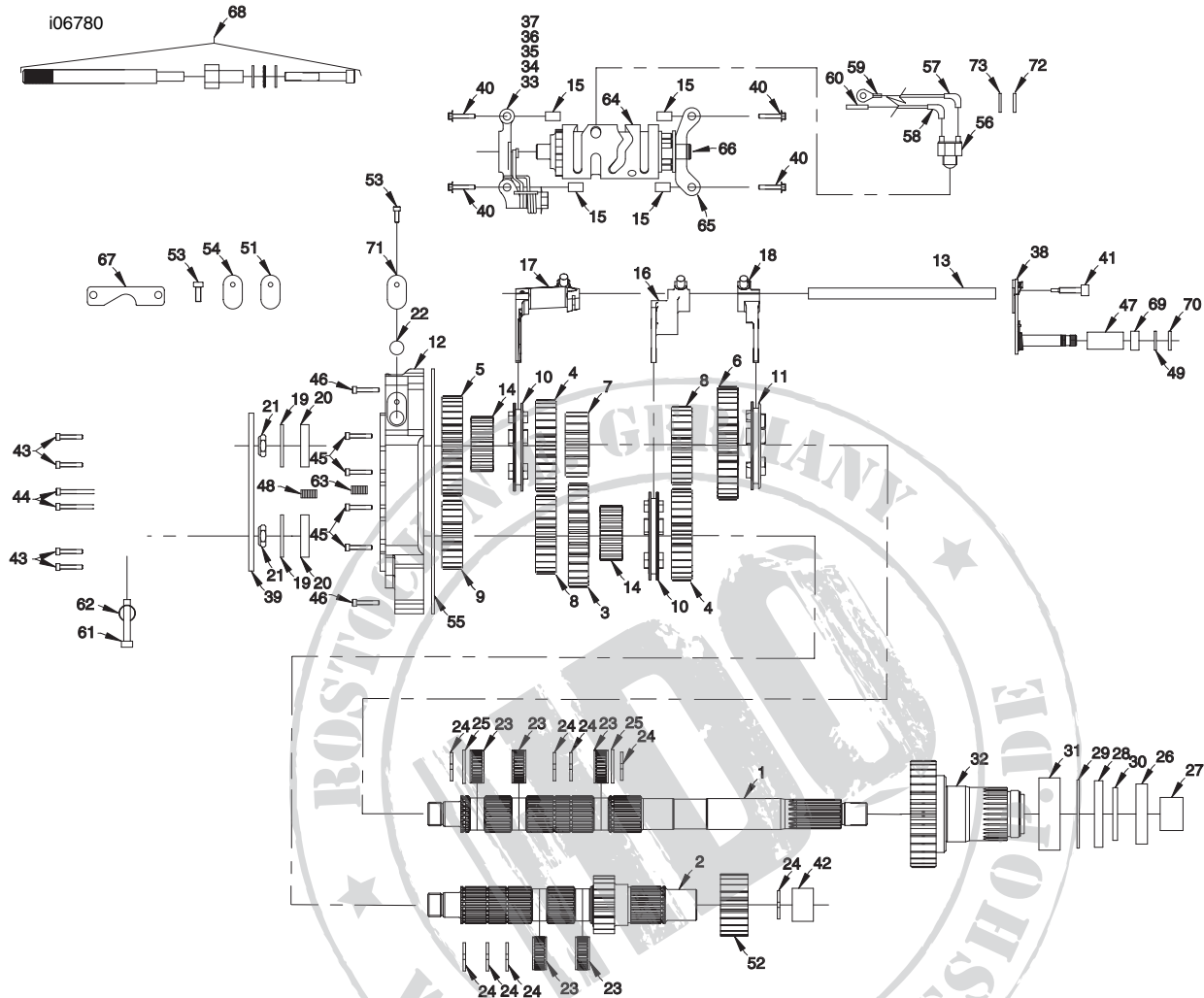

- | | | | |
|---|--|--|---|
| <ul style="list-style-type: none"> 1. Mainshaft 2. Countershaft 3. Countershaft 1st Gear 4. Mainshaft 3rd Gear/
Countershaft 2nd Gear (2) 5. Mainshaft 4th Gear 6. Mainshaft 6th Gear 7. Mainshaft 1st Gear 8. Countershaft 3rd Gear/
Mainshaft 2nd Gear (2) 9. Countershaft 4th Gear 10. Shift Ring, 1-2, 3-4 (2) 11. Shift Ring, 5-6 12. Chrome Side Door w/Ear 13. Shifter Fork Shaft 14. Splined Sleeve (2) 15. Pillow Block Dowel (4) 16. Shifter Fork, 1-2 17. Shifter Fork, 3-4 18. Shifter Fork, 5-6 19. Door Retaining Ring (2) 20. Trap Door Bearing (2) 21. Mainshaft/Countershaft
Locknut (2) 22. Speedo Sensor O-Ring (2) 23. Split Cage Bearing (5) 24. Mainshaft/Countershaft
Retaining Ring (8) | <ul style="list-style-type: none"> 25. Mainshaft Thrust Washer (2) 26. Sprocket Spacer 27. Mainshaft Race 28. Main Case Seal 29. Case Bearing Retaining Ring 30. Quad Seal 31. Main Case Bearing 32. Main Shaft, 5th Gear 33. Right Pillow Block 34. Detent Arm Screw 35. Detent Sleeve 36. Detent Follower 37. Detent Arm Spring 38. Shifter Shaft Assembly 39. Side Cover Gasket 40. Pillow Block Screw (4) 41. Shifter Centering Screw 42. Countershaft Bearing 43. Clutch Release Cover
Lower Screw (4) 44. Clutch Release Cover
Upper Screw (2) 45. Lower Trap Door Screw (4) 46. Upper Trap Door Screw (2) 47. Shifter Shaft Sleeve 48. Side Door Plug, Magnetic | <ul style="list-style-type: none"> 49. Shifter Seal Washer 50. Shifter Fork Shaft Screw 51. Sensor Plate Gasket 52. Countershaft 5th Gear 53. Speedo Sensor Plate Screw (2) 54. Sensor Plate 55. Trap Door Gasket 56. Neutral Switch 57. Wire Assembly (Black) 58. Wire Assembly (Tan) 59. 1/4 Inch Ring Terminal (18-20 ga.) 60. Connector (18-20 ga.) 61. Chrome Dipstick 62. Dipstick O-Ring
(1ea. FXST, 2ea. FXD) 63. Trap Door Plug-Non Magnetic
(Drain for 91-00 FXD Only) 64. Shift Drum Assembly 65. Left Pillow Block 66. Shift Drum Retainer 67. Case Modification Tool 68. Tool (Remove/Install Shifter Shaft
Sleeve) 69. Shifter Seal 70. Shifter retaining Ring | <ul style="list-style-type: none"> 71. Speedo Sensor Plug 72. Nylon Washer 73. Washer <p>Items Not Shown:</p> <ul style="list-style-type: none"> Lid Gasket, FXST Lid Gasket, FXD 1991-98 Lid Gasket, FXD 1999-00 Fill Spout Gasket, FXD 1991-98 Oil Fill Spout Lower O-Ring, FXD Oil Stick O-Ring, FXD (2) |
|---|--|--|---|



Service Parts

Part No. 33100-03A

Date 08/04

6 Speed Transmission Super Kit

Item QuantityPart No.

1.	Mainshaft 1	35058-03
2.	Countershaft 1	35059-03
3.	Countershaft 1st Gear 1	35080-03
4.	Mainshaft 3rd Gear/Countershaft 2nd Gear 2	35083-03
5.	Mainshaft 4th Gear 1	35104-03
6.	Mainshaft 6th Gear 1	35131-03
7.	Mainshaft 1st Gear 1	35134-03
8.	Countershaft 3rd Gear/ Mainshaft 2nd Gear 2	35135-03
9.	Countershaft 4th Gear 1	35136-03
10.	Shift Ring, 1-2, 3-4 2	35137-03
11.	Shift Ring, 5-6 1	35138-03
12.	Trap Door 1	35139-03
13.	Shifter Fork Shaft 1	34088-87A
14.	Splined Sleeve 2	35140-03
15.	Pillow Block Dowel 4	609
16.	Shifter Fork, 1-2 1	35143-03
17.	Shifter Fork, 3-4 1	35144-03
18.	Shifter Fork, 5-6 1	35145-03
19.	Door Retaining Ring 2	35087-99
20.	Trap Door Bearing 2	8992A
21.	Mainshaft/Countershaft Locknut 2	35078-79
22.	Speedo Sensor O-Ring 2	11289A
23.	Split Cage Bearing 5	8876A
24.	Mainshaft/Countershaft Retaining Ring 8	11067
25.	Mainshaft Thrust Washer 2	6003
26.	Sprocket Spacer 1	33344-94
27.	Mainshaft Race 1	34091-85A
28.	Main Case Seal 1	12067B
29.	Case Bearing Retaining Ring 1	11161
30.	Quad Seal 1	11165
31.	Main Case Bearing 1	8996A
32.	Main Shaft, 5th Gear 1	35237-03
33.	Right Pillow Block 1	33304-00
34.	Detent Arm Screw 1	33376-00
35.	Detent Sleeve 1	33375-00A
36.	Detent Follower 1	33364-00A
37.	Detent Arm Spring 1	33374-00
38.	Shifter Shaft Assembly 1	35146-03
39.	Side Cover Gasket 1	35148-03
40.	Pillow Block Screw4	3909
41.	Shifter Centering Screw1	34978-00A
42.	Countershaft Bearing 1	8977
43.	Clutch Release Cover Lower Screw 4	4718A
44.	Clutch Release Cover Upper Screw2	4717A
45.	Trap Door Screw, Lower4	3249
46.	Trap Door screw, Upper2	4814A
47.	Sleeve1	34979-00
48.	Side Door Plug, Magnetic1	739A
49.	Shifter Seal Washer1	6497HW
50.	Shift Fork Shaft Screw1	3784
51.	Sensor Plate Gasket1	35152-03
52.	Countershaft Gear, 5th1	Not sold
53.	Speedo Sensor Plate Screw2	3594
54.	Plate Sensor1	35153-03
55.	Trap Door gasket1	35147-03
56.	Neutral Switch1	33904-00A
57.	Wire Assembly (Black)1	72405-98BK



Service Parts

Part No. 33100-03A

Date 08/04

6 Speed Transmission Super Kit

Item QuantityPart No.

58. Wire Assembly (Tan)1	72405-98TN
59. 1/4 Inch Ring Terminal (14-18 ga.)1	72241-94A
60. Connector (18-20 Gauge)1	70585-93
61. Chrome Dipstick1	37075-87
62. Dipstick O-Ring (2ea. FXST and 1ea. FXD)2	11132
63. Trap Door Plug (Drain for 91-00 FXD Only)1	45830-48
64. Shift Drum Assembly 1	35142-03
65. Left Pillow Block1	33301-00A
66. Shift Drum Retainer1	11342
67. Case Modification Tool1	35155-03
68. Tool (Remove/Install Shifter Shaft Sleeve)1	Not sold
69. Shifter Seal1	12045
70. Shifter Retainer Ring1	11150
71. Speedo Sensor plug1	35239-03
72. Nylon Washer1	33043-80
73. Washer1	6288

Items Not Shown:

- Lid Gasket, FXST134904-86D
- Lid Gasket, FXD 1991-98134917-90B
- Lid Gasket, FXD 1999-00134917-99B
- Oil Fill Spout Gasket, FXD 1991-98162423-90A
- Oil Fill Spout Lower O-Ring, FXD162672-90
- Oil Stick O-Ring, FXD 262673-90

