



INSTRUCTIONS

-J06196

2016-03-28

SCREAMIN' EAGLE 10MM SPARK PLUG WIRES

GENERAL

Kit Number

31600048A, 31600051A, 31600054A

Models

For model fitment information, see the P&A retail catalog or the Parts and Accessories section of www.harley-davidson.com (English only).

Kit Contents

See Figure 3 and Table 1.

⚠ WARNING

The rider's safety depends upon the correct installation of this kit. Use the appropriate service manual procedures. If the procedure is not within your capabilities or you do not have the correct tools, have a Harley-Davidson dealer perform the installation. Improper installation of this kit could result in death or serious injury. (00333a)

NOTE

This instruction sheet refers to service manual information. A service manual for your year/model motorcycle is required for this installation. One is available from a Harley-Davidson dealer.

⚠ WARNING

Disconnecting spark plug cable with engine running can result in electric shock and death or serious injury. (00464b)

REMOVAL

1. See the service manual. Remove seat.

NOTE

Remove cable by pulling on rubber boot only. Do not pull on cable or damage can result.

Pull and twist simultaneously to remove rubber boot.

2. See Figure 1. Remove front spark plug cable (1). Remove rear spark plug cable (2).
3. Remove rear spark plug cable from retaining clips (3).

INSTALLATION

1. See Figure 3. Apply dielectric grease (4) to the insides of the coil boot (A) and spark plug boots (B).

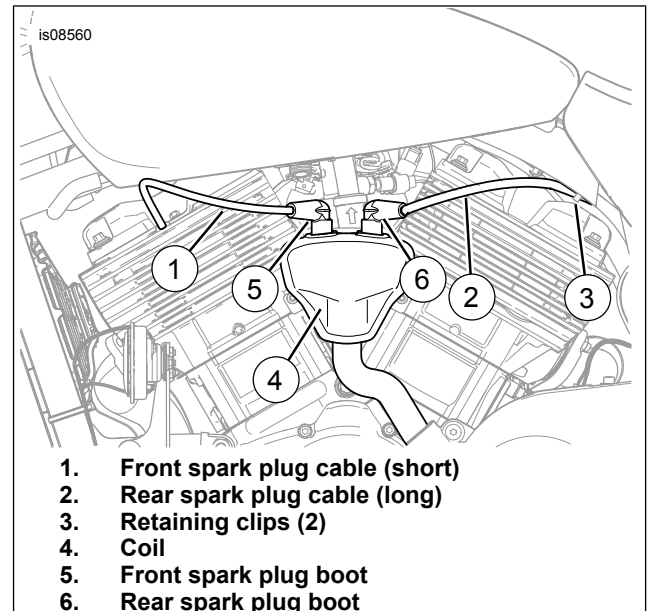

Figure 1. Spark Plug Cables

2. See Figure 1. Install new front spark plug cable (1) to spark plug. Push the spark plug boot onto spark plug until it snaps into place. Rotate front cable boot (5) until it is parallel to the motorcycle centerline. Install new front spark plug cable boot to the ignition coil (4). Gently pull upward to verify spark plug cables are locked into place.

NOTE

Incorrectly installed spark plug cables lead to poor engine performance due to lack of spark to one or both cylinders.

3. Install new rear spark plug boot (6) to the ignition coil. Route the spark plug cable using the path of the old spark plug cable.



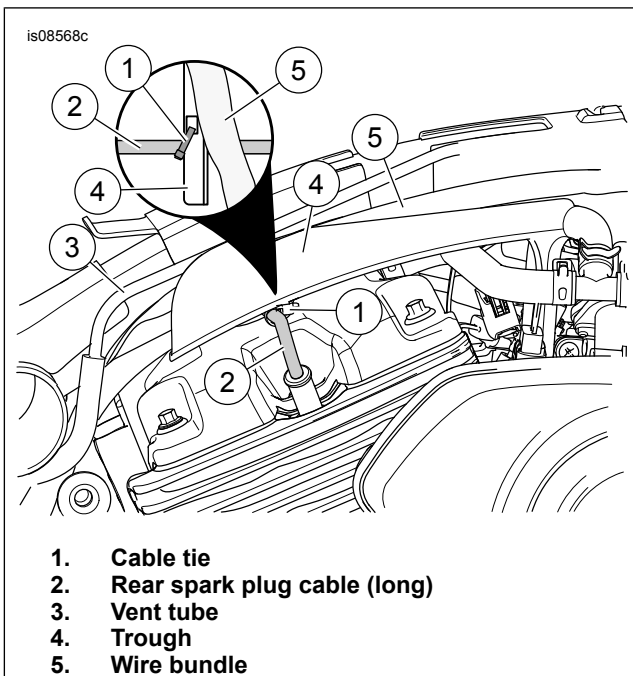

Figure 2. Secure Spark Plug Cable (shown without fuel tank and seat for clarity)

- See Figure 2. Install new front spark plug cable (2) to spark plug. Push the spark plug end in far enough to feel it snap into place. Gently pull upward to verify spark plug cables are locked into place.
- Slide cable strap (1) through square hole in trough (4) and around spark plug wire (1) as shown. Do not route cable strap around wire bundle (5) or tube (3). Tighten cable strap and trim cable strap as needed. Repeat step for front spark plug cable on other side.

⚠ WARNING

After installing seat, pull upward on seat to be sure it is locked in position. While riding, a loose seat can shift causing loss of control, which could result in death or serious injury. (00070b)

- See the service manual. Install seat.

SERVICE PARTS

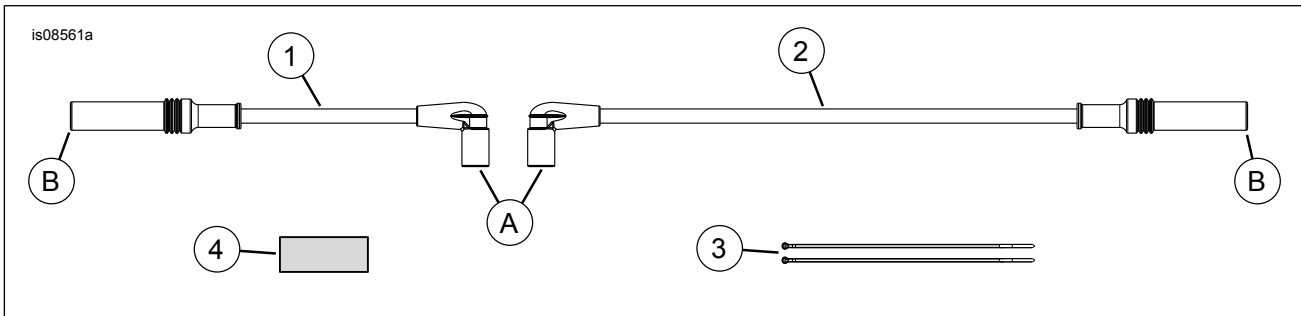

Figure 3. Service Parts: Screamin Eagle 10 MM Spark Plug Cables

Table 1. Service Parts

Kit	Item	Description (Quantity)	Part Number
31600048A	1	Spark plug cable, black, short	Not sold separately
	2	Spark plug cable, black, long	Not sold separately
	3	Cable strap (2)	Not sold separately
	4	Dielectric grease	Not sold separately
31600051A	1	Spark plug cable, orange, short	Not sold separately
	2	Spark plug cable, orange, long	Not sold separately
	3	Cable strap (2)	Not sold separately
	4	Dielectric grease	Not sold separately
31600054A	1	Spark plug cable, red, short	Not sold separately
	2	Spark plug cable, red, long	Not sold separately
	3	Cable strap (2)	Not sold separately
	4	Dielectric grease	Not sold separately
Items mentioned in text.			
	A	Coil boot	
	B	Spark plug boot	