



# INSTRUCTIONS

-J06272

2016-05-17

## TOURING STARTER COVER

### GENERAL

#### Kit Numbers

31400088, 31400090

#### Models

For model fitment information, see the P&A retail catalog or the Parts and Accessories section of [www.harley-davidson.com](http://www.harley-davidson.com) (English only).

#### Installation Requirements

Loctite<sup>®</sup> 243 Medium Strength Threadlocker and Sealant - Blue (Part No. 99642-97) is required for proper installation of this kit.

#### ▲ WARNING

The rider's safety depends upon the correct installation of this kit. If the procedure is not within your capabilities or you do not have the correct tools, have a Harley-Davidson dealer perform the installation. Improper installation of this kit could result in death or serious injury. (00308a)

#### NOTE

This instruction sheet refers to service manual information. A service manual for your year/model motorcycle is available from a Harley-Davidson dealer.

#### Kit Contents

See Figure 1 and Table 1

#### PREPARATION

#### ▲ WARNING

To prevent accidental vehicle start-up, which could cause death or serious injury, remove main fuse before proceeding. (00251b)

#### NOTE

- **WITH security siren:** With security fob present, turn ignition switch ON. See the service manual. Disarm security system. Turn ignition switch OFF. **IMMEDIATELY** remove the main fuse.
- **WITHOUT security siren:** See the service manual. Remove main fuse.

1. Remove seat. Retain all seat mounting hardware.

#### ▲ WARNING

Disconnect negative (-) battery cable first. If positive (+) cable should contact ground with negative (-) cable connected, the resulting sparks can cause a battery explosion, which could result in death or serious injury. (00049a)

2. Disconnect both battery cables, negative battery cable first.
3. Verify that the positive battery cable rubber boot at the starter terminal is in place and in good condition. Verify that the cable is routed correctly.

#### INSTALLATION

1. See Figure 1. Remove three adhesive pad liners (C) from the inboard side of the cover mounting bracket (1).
2. Rotate the mounting bracket into approximate position, aligned with the starter motor (A) as shown.
3. Engage the lower tab (B) with the lower starter bolt lug. Rotate the bracket into position. Use a small pry bar to lift the tabs gently over the starter cap to prevent scratching.
4. Apply a few drops of Loctite 243 - Blue to the clean threads of the two button head screws (3).
5. Place the starter cover (2) over the cover mounting bracket, aligning the holes to the mounting tabs.
6. Install the cover to the bracket with the two screws. Tighten to button head screw 16-18 in-lbs 1.8.2.1 N-m.

#### COMPLETION

#### NOTE

Verify that the ignition switch is in the OFF position **before** attaching the battery cables.

#### ▲ WARNING

Connect positive (+) battery cable first. If positive (+) cable should contact ground with negative (-) cable connected, the resulting sparks can cause a battery explosion, which could result in death or serious injury. (00068a)

1. See the service manual. Attach the battery cables (positive cable first). Apply a light coat of petroleum jelly or corrosion retardant material to battery terminals.

#### ▲ WARNING

After installing seat, pull upward on seat to be sure it is locked in position. While riding, a loose seat can shift causing loss of control, which could result in death or serious injury. (00070b)

2. Refer to the service manual. Install seat.
3. Install main fuse.

-J06272



Many Harley-Davidson® Parts & Accessories are made of plastics and metals which can be recycled. Please dispose of materials responsibly.

1 / 2

## SERVICE PARTS

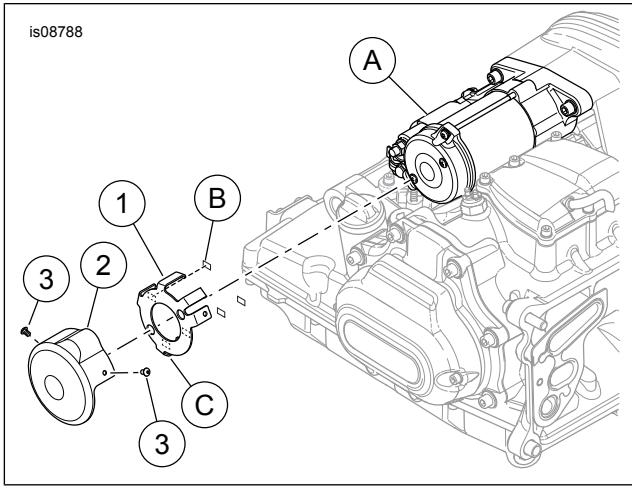

Figure 1. Service Parts, Touring Starter Cover

Table 1. Service Parts

Item	Description (Quantity)	Part Number
1	Mounting bracket, starter motor	31400069
2	Cover, starter motor	Not sold separately
3	Screw, button head (2), #8-32 x 6.4 mm (0.25 in) long, stainless steel	10200534
<b>Items mentioned in text, but not included in kit.</b>		
A	Starter motor	
B	Adhesive pad liner (3)	
C	Mounting bracket lower tab	