



INSTRUCTIONS

-J05052

REV. 2009-09-08

SCREAMIN' EAGLE XL 883 TO 1200 STAGE 1 CONVERSION KIT

GENERAL

Kit Number

30003-10

Models

For model fitment information, see the P&A Retail Catalog or the Parts and Accessories section of www.harley-davidson.com (English only).

Additional Parts Required

This kit requires the separate purchase of the following tools which are available from a Harley-Davidson dealer.

- Piston Pin Lock Ring Remover/Installer HD-34623-C
- Piston Pin Remover HD-42320-A
- Piston Support Plate HD-42322

Proper installation of this kit requires the use of Digital Technician™ at a Harley-Davidson dealer.

WARNING

The rider's safety depends upon the correct installation of this kit. Use the appropriate service manual procedures. If the procedure is not within your capabilities or you do not have the correct tools, have a Harley-Davidson dealer perform the installation. Improper installation of this kit could result in death or serious injury. (00333a)

NOTE

This instruction sheet references service manual information. A service manual for your model motorcycle is required for this installation and is available from a Harley-Davidson dealer.

Kit Contents

See Figure 1 to Figure 3 and Table 1 to Table 3.

NOTES

Installation of this kit by an authorized Harley-Davidson dealer will not impact your limited vehicle warranty.

This Big Bore Stage 1 kit is intended for High Performance applications only.

This engine related performance part is legal for sale or use in California on pollution controlled motor vehicles.

Engine related performance parts are intended for the experienced rider only.

For 2008 and Later Models: New emissions tune-up labels are included as a requirement of the California Air Resource Board (CARB) emissions regulation. Select the label that matches the year of the vehicle, and place the new label over

the upper part of the original emissions tune-up label. This replacement label is not required outside the state of California.

The air cleaner contained in this kit is designed to perform with this kit only. Any other combination of components is not confirmed to be legal for street use.

REMOVAL

NOTE

If vehicle is equipped with Harley-Davidson Smart Security System, see owner's manual for instructions to disarm the system.

WARNING

When servicing the fuel system, do not smoke or allow open flame or sparks in the vicinity. Gasoline is extremely flammable and highly explosive, which could result in death or serious injury. (00330a)

1. Remove left side cover and the main fuse. Refer to MAIN FUSE REMOVAL in service manual.
2. Remove existing air cleaner assembly. Refer to AIR CLEANER REMOVAL in service manual.
3. Remove cylinder heads, cylinders, and pistons. Refer to appropriate ENGINE sections in service manual.
4. Remove clutch components. Refer to DRIVE/TRANSMISSION section in service manual.

INSTALLATION

Install Engine and Clutch Components

NOTES

The 1200 cc pistons have an arrow on the top of the piston. This arrow must face the front of the engine when piston is installed. There is no front cylinder piston or rear cylinder piston. New pistons can be installed in either cylinder.

Check piston rings for proper side clearance and end gap. Be sure end gaps of adjacent rings are installed 90 degrees apart.

1. Install cylinder heads, cylinders, and pistons from kit. Refer to appropriate ENGINE sections in service manual.
2. Install clutch components. Replace original gaskets, O-rings, and seals with new components from kit. Refer to DRIVE/TRANSMISSION section in service manual.
3. Install air cleaner assembly. Refer to instructions included with Air Cleaner Kit (29042-04B) on Instruction Sheet J03663.

Recalibrate ECM

CAUTION

You must recalibrate the ECM when installing this kit. Failure to properly recalibrate the ECM can result in severe engine damage. (00399b)

Download the new ECM calibration using the Digital Technician™ at a Harley-Davidson dealer.

Return to Service

Install the main fuse and left side cover. Refer to the MAIN FUSE INSTALLATION in service manual.

OPERATION

Refer to BREAK-IN RIDING RULES in owner's manual for instructions to break-in the motorcycle.

SERVICE PARTS

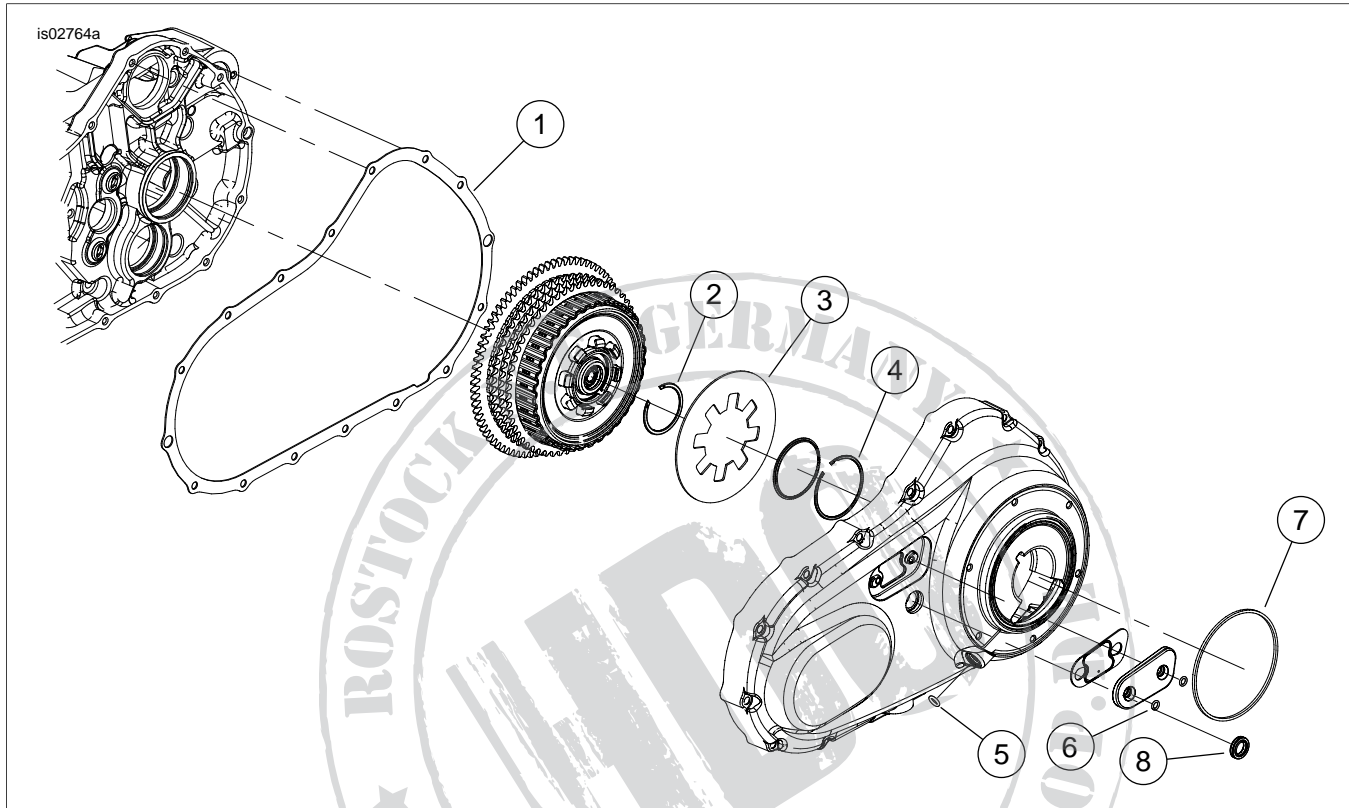

Figure 1. Service Parts: Screamin' Eagle XL 833 to 1200 Stage 1 Conversion Kit

Table 1. Service Parts: Screamin' Eagle XL 833 to 1200 Stage 1 Conversion Kit

Item	Description (Quantity)	Part Number	Item	Description (Quantity)	Part Number
1	Gasket, primary cover	34955-04	6	O-ring (2)	11171
2	Retaining ring, clutch plate	37909-90	7	Gasket, clutch inspection cover	25463-94A
3	Spring, clutch plate	37924-04A	8	Seal, oil	37107-06
4	Retaining ring	37908-90	9	Air Cleaner Kit (Not Shown)	29042-04C
5	O-ring, clutch cable	11179			

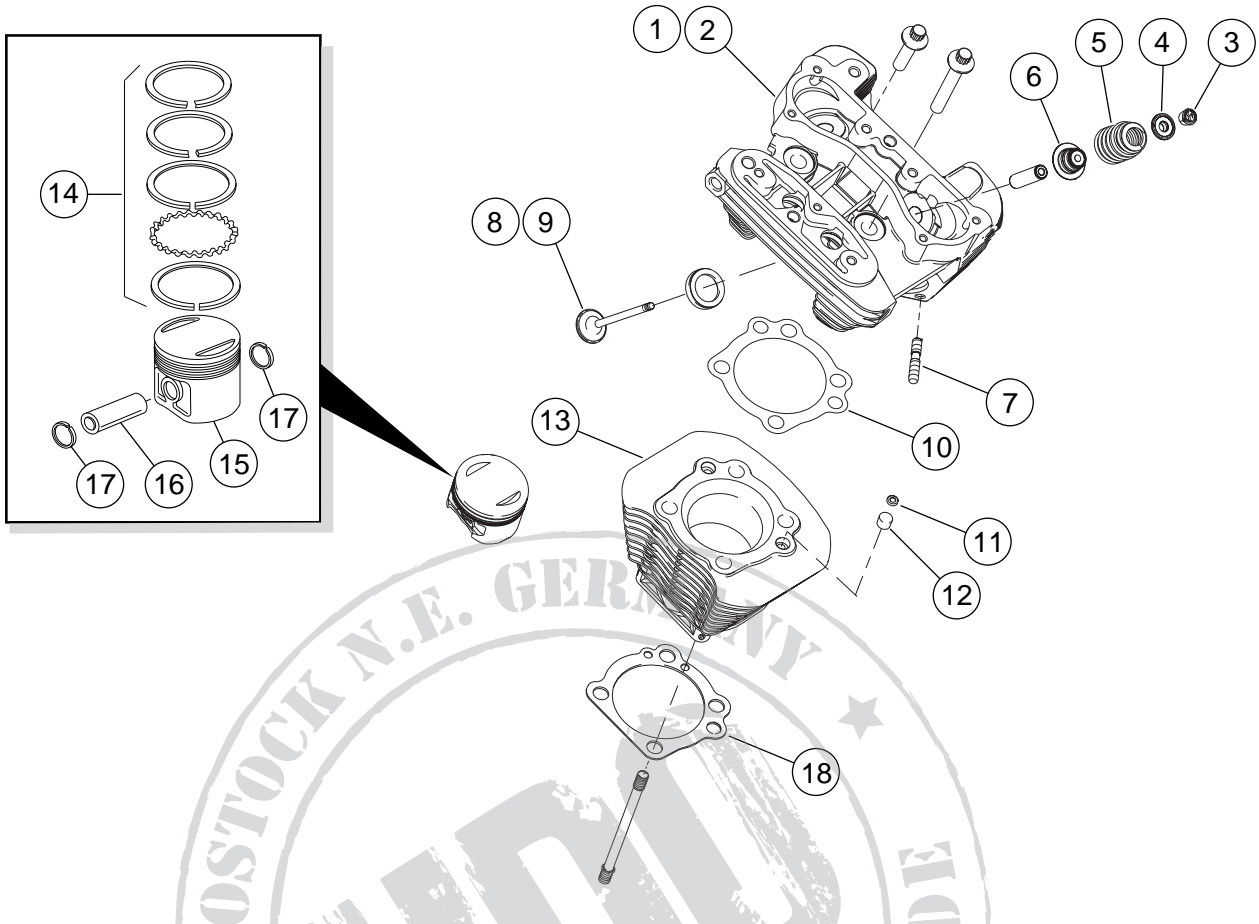

Figure 2. Service Parts: Screamin' Eagle XL 883 to 1200 Stage 1 Conversion Kit

Table 2. Service Parts: Screamin' Eagle XL 883 to 1200 Stage 1 Conversion Kit

Item	Description (Quantity)	Part Number	Item	Description (Quantity)	Part Number
1	Cylinder head, rear, machined, with seats & guides, black, non-highlighted	17488-07	11	O-ring, cylinder stud insert (4)	26432-76A
2	Cylinder head, front, machined, with seats & guides, black, non-highlighted	17485-07	12	Dowel (4)	16573-83A
3	Keeper, valve collar (8)	18260-02	13	Cylinder black, std., non-highlighted (2)	Not Sold Separately
4	Collar, valve spring, upper (4)	18258-02	14	Piston Ring Set, 1200, std. (2)	21948-02
5	Spring, valve (4)	18245-02	15	Piston, 1200, std. (2)	22650-04A
6	Seal, valve (4)	18094-02A	16	Piston pin (2)	22765-02
7	Stud, exhaust port (4)	16715-83	17	Retaining ring (4)	22589-83B
8	Valve, intake (2)	18690-02	18	Gasket, cylinder base (2)	16789-04
9	Valve, exhaust (2)	18691-02	19	Seal, intake manifold (Not Shown)	26995-86B
10	Gasket, cylinder head (2)	16770-84F	20	Seal, exhaust (Not Shown)	17048-98

NOTE: Item 13 is available in the Cylinder w/Piston and Rings Kit, std., 16469-10, which includes items 14 through 17.

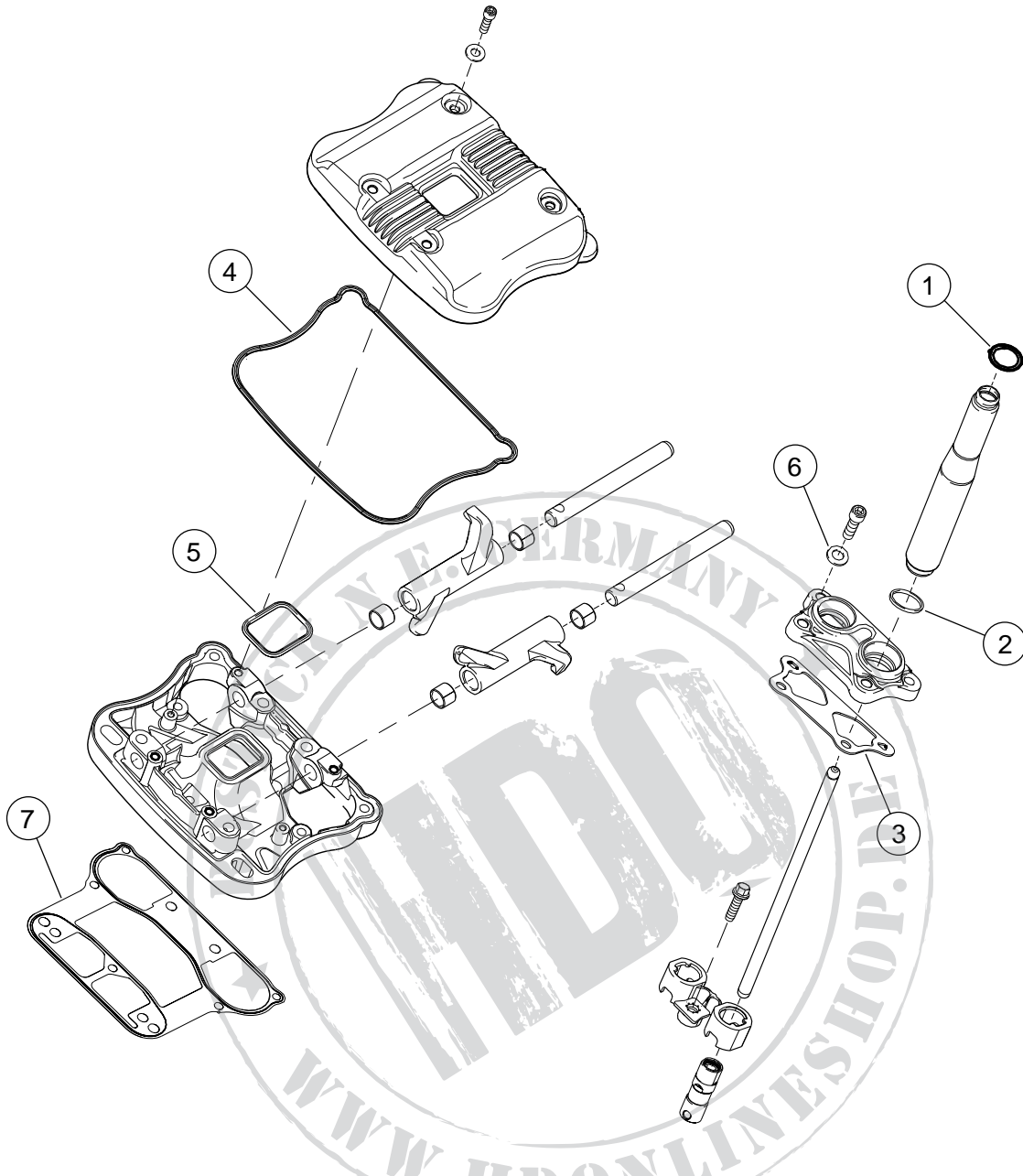

Figure 3. Service Parts: Screamin' Eagle XL 883 to 1200 Stage 1 Conversion Kit

Table 3. Service Parts: Screamin' Eagle XL 883 to 1200 Stage 1 Conversion Kit

Item	Description (Quantity)	Part Number	Item	Description (Quantity)	Part Number
1	O-ring, upper push rod cover (4)	11190	5	Gasket, rocker cover, inner (2)	17695-07A
2	O-ring, tappet cover (4)	11377	6	Seal washer, tappet cover (8)	6589
3	Gasket, tappet cover (2)	17976-04	7	Gasket, rocker box (2)	16800-84A
4	Gasket, rocker cover, lower (2)	17362-07A			