



INSTRUCTIONS

-J04458

REV. 2007-06-27

SCREAMIN EAGLE STAGE 1 BIG BORE KIT FOR EFI MODELS

GENERAL

Kit Number

27535-08, 27536-08, 27539-08, 27540-08, 29903-07A, 29904-07A

Models

These kits fit 2007-2008 EFI Softail, 2008 EFI Dyna and 2008 EFI Touring model motorcycles.

Additional Parts Required

Proper installation of this kit requires the use of Digital Technician™ at a Harley-Davidson dealer.

WARNING

The rider's safety depends upon the correct installation of this kit. Use the appropriate service manual procedures. If the procedure is not within your capabilities or you do not have the correct tools, have a Harley-Davidson dealer perform the installation. Improper installation of this kit could result in death or serious injury. (00333a)

NOTE

This instruction sheet references Service Manual information. A Service Manual for your model motorcycle is required for this installation and is available from a Harley-Davidson dealer.

Kit Contents

See Figure 1, Table 1 and Figure 2, Table 2.

NOTES

Installation of this kit by an authorized Harley-Davidson dealer will not impact your limited vehicle warranty.

This Big Bore Stage 1 kit is intended for High Performance applications only. This engine related performance part is legal for sale or use in California on pollution controlled motor vehicles. Engine related performance parts are intended for the experienced rider only.

The Product Information Label contained in this kit is a requirement of the California Air Resource Board (CARB) emission regulation for all 2007 Touring models and 2007-2008 Dyna and Softail models. Place the label on the right side of the frame directly beneath the VIN sticker. This label is not required outside the state of California.

The air cleaner contained in this kit is designed to perform with this kit only. Any other combination of components is not confirmed to be legal for street use.

REMOVAL

WARNING

To prevent accidental vehicle start-up, which could cause death or serious injury, remove maxi-fuse before proceeding. (00251a)

1. All Models:
 - a. Remove Maxi® fuse. Refer to MAXI® FUSE REMOVAL in Service Manual.

NOTE

Head gaskets provided in the 1690 conversion kit eliminate the need for original equipment (O.E.) O-rings. Do not install the two O-rings from the kit on the top cylinder dowels or severe engine damage can occur.

WARNING

When servicing the fuel system, do not smoke or allow open flame or sparks in the vicinity. Gasoline is extremely flammable and highly explosive, which could result in death or serious injury. (00330a)

2. Remove existing cylinder heads, cylinders, and pistons. Refer to ENGINE section in appropriate Service Manual.
3. Remove existing primary chaincase cover, diaphragm spring retainer, and clutch diaphragm spring. Refer to DRIVE section in appropriate Service Manual.

INSTALLATION

Install Pistons, Cylinders, and Clutch Components

1. Install pistons, cylinders, and cylinder heads from kit. Refer to ENGINE section in appropriate Service Manual.
2. Install diaphragm spring retainer, clutch diaphragm spring (Table 2, item 15) and primary chaincase cover. Refer to DRIVE section in appropriate Service Manual.

Install High Performance Air Cleaner

Refer to instructions included with Air Cleaner Kit 29440-99D, 29260-08 or 29406-08 depending on your model motorcycle.

Final Assembly

1. *All Models:*
 - a. Install Maxi® fuse. Refer to MAXI® FUSE REMOVAL in Service Manual.

WARNING

After installing seat, pull upward on seat to be sure it is locked in position. While riding, a loose seat can shift causing loss of control, which could result in death or serious injury. (00070b)

Recalibrate ECM

CAUTION

You must recalibrate the ECM when installing this kit. Failure to properly recalibrate the ECM can result in severe engine damage. (00399b)

Download the new ECM calibration using the Digital Technician™ at a Harley-Davidson dealer.



SERVICE PARTS

is03129

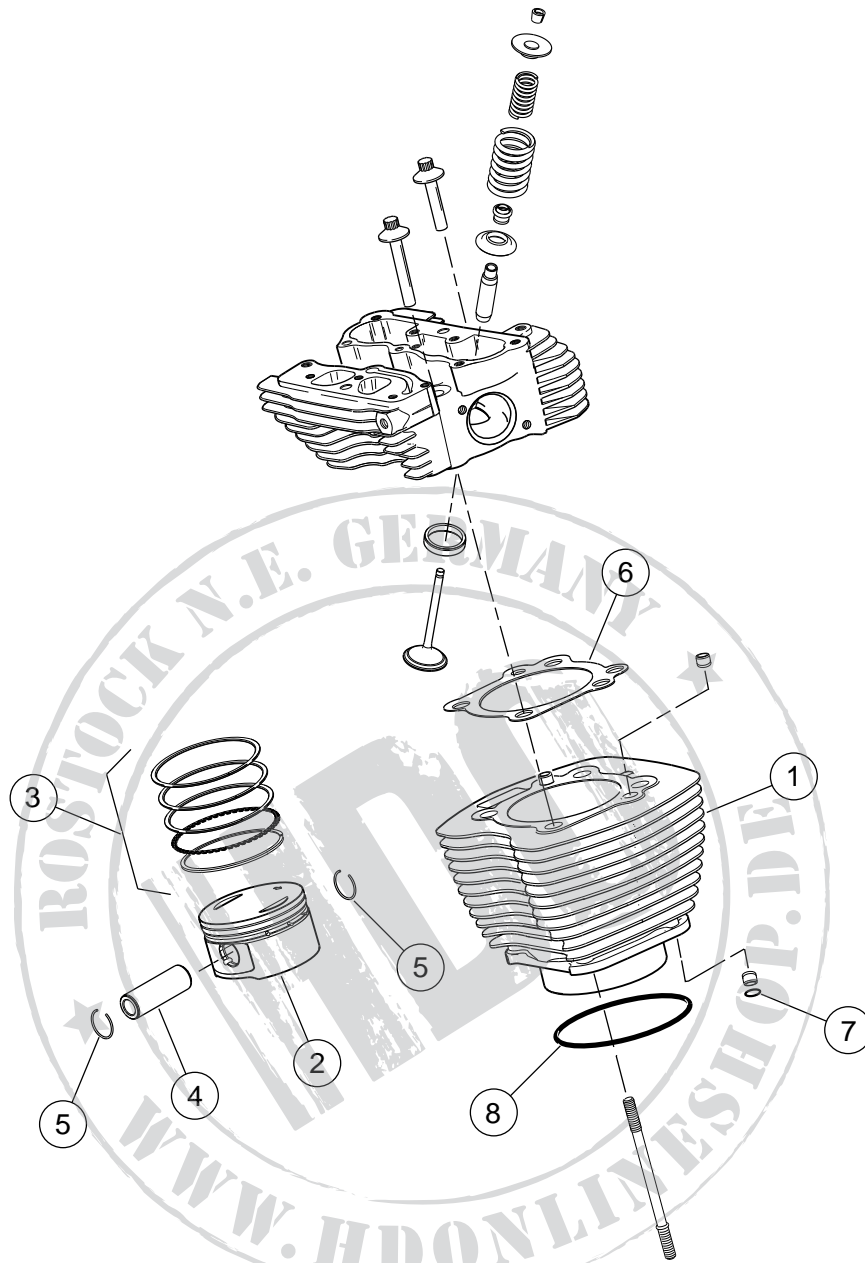

Figure 1. Service Parts: Screamin' Eagle Big Bore Stage 1 Kit

Table 1. Service Parts: Screamin' Eagle Big Bore Stage 1 Kit

Item	Description (Quantity)	Part Number	Item	Description (Quantity)	Part Number
1	Cylinder assembly (Silver) (2)	16548-99	5	Piston pin circlip (4)	22097-99
	Cylinder assembly (Black) (2)	16547-99	6	Head gasket (2)	16787-99A
2	Piston (2)	Not Sold Separately	7	O-ring, cylinder deck ring dowel (2)	11273
3	Piston ring set (2)	21918-99	8	O-ring, cylinder spigot (2)	11256
4	Piston pin (2)	22131-05	Note: Do not install O-ring (item 7) to top cylinder dowels.		

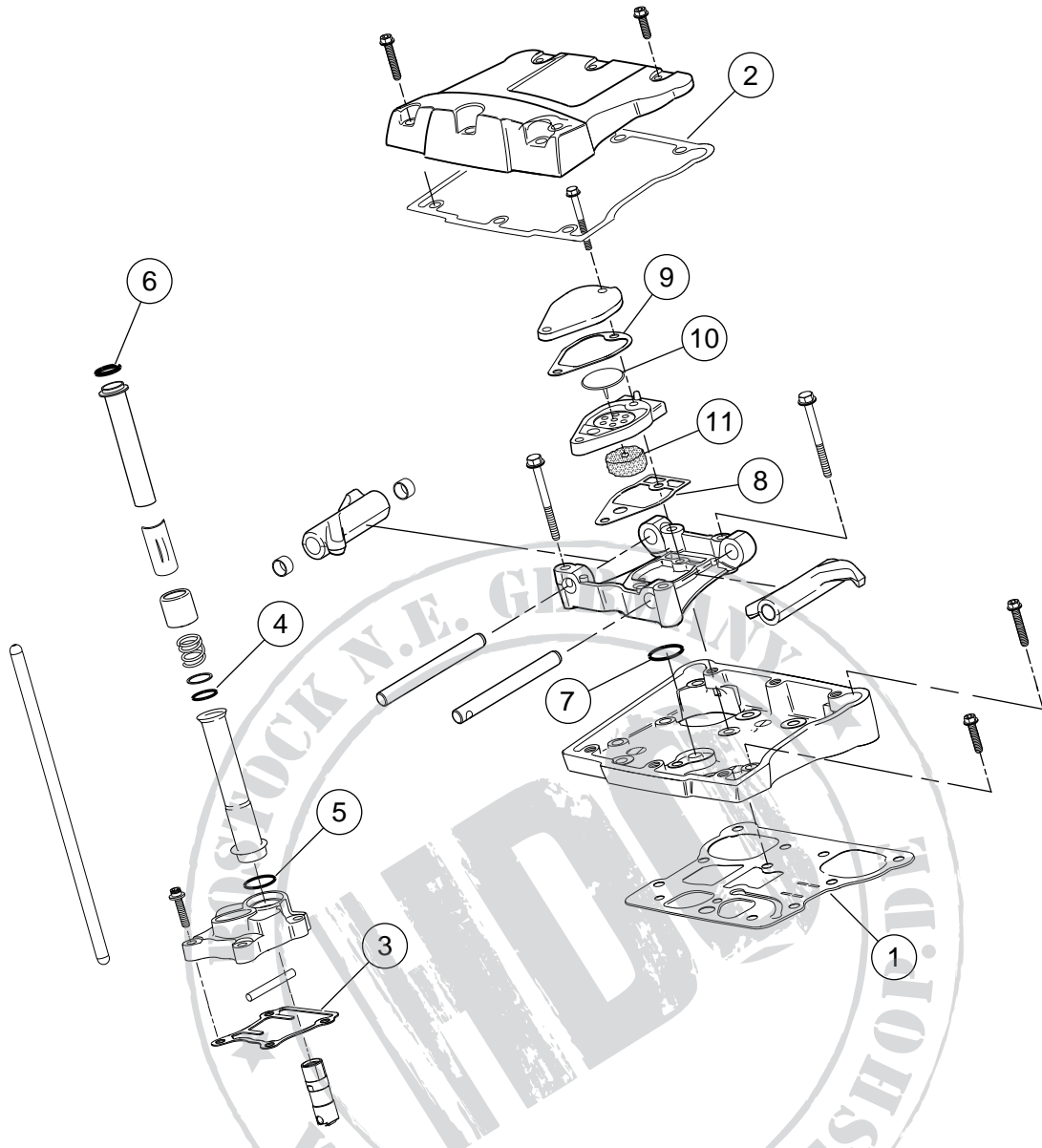

Figure 2. Service Parts: Screamin' Eagle Big Bore Stage 1 Kit

Table 2. Service Parts: Screamin' Eagle Big Bore Stage 1 Kit

Item	Description (Quantity)	Part Number	Item	Description (Quantity)	Part Number
1	Gasket, rock cover base (2)	16719-99A	10	Umbrella valve (2)	26858-99
2	Gasket, rocker cover top (2)	17386-99A	11	Filter element, breather (2)	63815-99
3	Gasket, tappet cover (2)	18635-99B	12	Seal, exhaust (Not Shown)	17048-98
4	O-ring, middle push rod cover (4)	11132A	13	Seal, EFI intake (2) (Not Shown)	26995-86B
5	O-ring, lower push rod cover (4)	11145A	14	Valve seal kit (Not Shown)	18004-86
6	O-ring, upper push rod cover (4)	11293	15	Spring, clutch diaphragm (Not Shown)	37951-98
7	O-ring, rocker arm support (2)	11270	16	Air cleaner kits (Not Shown)	29440-99D 29260-08 29406-08
8	Gasket, breather (2)	Not Sold Separately	17	Product information label (Not Shown)	Not Sold Separately
9	Gasket, breather (2)	Not Sold Separately	--	Breather gasket kit (includes items 8 through 11)	17162-03