



# INSTRUCTIONS

-J06286

2016-08-22

## SCREAMIN' EAGLE PERFORMANCE AIR CLEANER KIT

### GENERAL

#### Kit Numbers

29400263, 29400264

#### Models

For model fitment information, see the P&A retail catalog or the Parts and Accessories section of [www.harley-davidson.com](http://www.harley-davidson.com) (English only).

#### NOTE

*These kits are intended for High Performance applications only. Engine-related performance parts are intended FOR THE EXPERIENCED RIDER ONLY.*

#### Installation Requirements

Loctite® 243 (Blue) Threadlocker and Sealant (Part No. 99642-97) is required for proper installation of this kit.

#### ⚠ WARNING

**The rider's safety depends upon the correct installation of this kit. Use the appropriate service manual procedures. If the procedure is not within your capabilities or you do not have the correct tools, have a Harley-Davidson dealer perform the installation. Improper installation of this kit could result in death or serious injury. (00333a)**

#### NOTE

*This instruction sheet references service manual information. A service manual for this year/model motorcycle is required for this installation. One is available from a Harley-Davidson dealer.*

#### NOTICE

**You must recalibrate the ECM when installing this kit. Failure to properly recalibrate the ECM can result in severe engine damage. (00399b)**

See a Harley-Davidson dealer for ECM (Electronic Control Module) calibration.

#### Kit Contents

See Figure 2 and Table 1.

### INSTALLATION

#### ⚠ WARNING

**Disconnect negative (-) battery cable first. If positive (+) cable should contact ground with negative (-) cable connected, the resulting sparks can cause a battery explosion, which could result in death or serious injury. (00049a)**

1. Refer to the service manual. Remove seat. Disconnect both battery cables, negative battery cable first. Save all seat mounting hardware.

#### ⚠ WARNING

**When servicing the fuel system, do not smoke or allow open flame or sparks in the vicinity. Gasoline is extremely flammable and highly explosive, which could result in death or serious injury. (00330a)**

#### Original Equipment (OE) Air Cleaner Removal

Have a Harley-Davidson dealer recalibrate the ECM before air cleaner installation.

1. Remove the air cleaner backplate following the instructions in the service manual.
2. See Figure 1. Remove and discard induction module support bracket. Secure throttle control wire to throttle body with supplied cable strap (A).

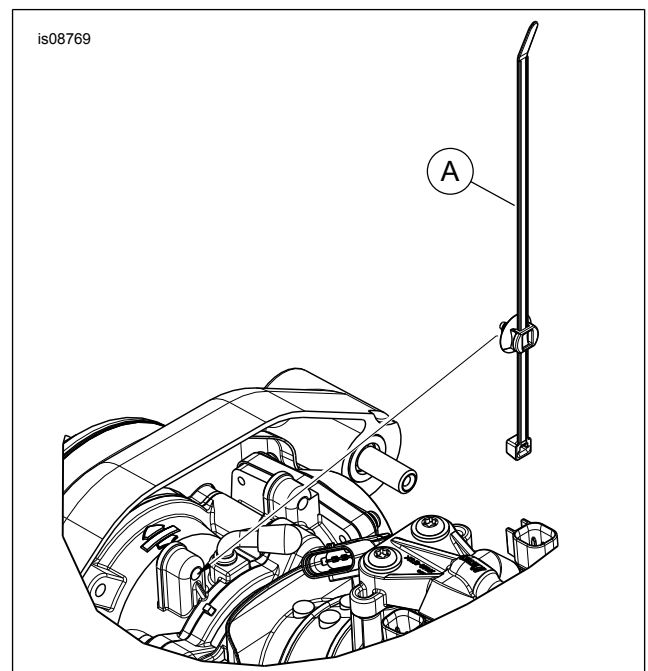

Figure 1. Cable Strap

#### Air Cleaner Installation

#### NOTE

*When servicing the air cleaner, apply Loctite 243 (blue) to all threaded fasteners (both male and female threads).*

1. Install throttle body cover (8) to back plate (6) with self-tapping screws (11).

2. Remove the backing from the adhesive side of the induction module backplate gasket (9). Align the holes. Install the gasket to the backplate (6).
3. Install the **new** square rings (7) in the counterbore around the breather screw holes on the induction module side of the backplate.
4. Align the holes in the induction module with the holes in the backplate.
5. Apply a small amount of Loctite to the backplate mounting screw (12) threads. Insert the screws through the backplate and into the induction module until the screw threads are engaged. DO NOT tighten now.
6. Install the **new** O-rings (5) in the counterbore around the breather screw holes on the air cleaner side of the backplate.
7. Insert the breather screws (3) through the backplate.
8. Alternately tighten the two breather screws.  
Torque: 13.6–16.3 N·m (120–144 **in-lbs**) screw
9. Tighten the three backplate mounting screws.  
Torque: 6.2–6.8 N·m (55–60 **in-lbs**) screw

## Air Filter Element and Intake Tube Installation

### NOTE

*This air filter is PRE-OILED and ready to install.*

1. Install the air filter element (13) onto the intake tube until it is fully seated in the groove. Tighten the clamp around the filter element flange.  
Torque: 5.2–6.2 N·m (45–55 **in-lbs**) screw
2. Line up the holes in the gasket (4) with the holes in the intake tube (2) flange.
3. Secure the intake tube and gasket to the air cleaner backplate. Tighten the screws (1).  
Torque: 6.2–6.8 N·m (55–60 **in-lbs**) screw

### NOTE

*Install the rain sock over the air filter element in wet or rainy conditions to prevent water intrusion.*

4. Install the rain sock (16) over the air filter element.

### ▲ WARNING

**Connect positive (+) battery cable first. If positive (+) cable should contact ground with negative (-) cable connected, the resulting sparks can cause a battery explosion, which could result in death or serious injury. (00068a)**

5. See the service manual to connect the battery cables, positive cable first.
6. See the service manual. Install seat. After installing seat, pull up on the seat to verify that it is secure.

## Air Filter Element Maintenance

1. Inspect the air filter element every:  
Distance: 8,000 km (5,000 mi)
  - a. Inspect more often under dusty conditions.
2. Replace air filter element every:  
Distance: 80,000 km (50,000 mi)

### NOTE

*\* The use of cleaning, drying or oiling methods or products other than those shown, damages the filter and can void the manufacturer's warranty.*

*\* K&N® Air Filter Cleaner is available from a Harley-Davidson dealer, either alone [0.95L (1 qt) sprayer bottle, Part No. 99883-88T] or as a 0.35L (12 fl oz) sprayer bottle as part of the Filter Care Service Kit (Part No. 99850-92T).*

*\* K&N Air Filter Oil is also available from a Harley-Davidson dealer, either alone [347 g (12.25 oz) aerosol can, Part No. 99882-88T] or as a 184 g (6.5 oz) aerosol can as part of the Filter Care Service Kit.*

*\* DO NOT OVER-OIL THE AIR FILTER. Over-oiling can interfere with the proper performance of the engine and/or certain engine components. If oil is still draining or dripping from the filter media 20 minutes after oiling, clean and oil the filter element again.*

3. To clean the element:
  - a. Loosen the hose clamp retaining the air filter element assembly to the air tube. Separate the element from the air tube.
  - b. Tap the element to dislodge any loose dirt. Gently brush with a soft bristle brush.
  - c. Spray air filter cleaner liberally onto the cotton filter media and let soak for ten minutes, OR roll or soak the cotton filter media in a shallow pan of air filter cleaner. Remove immediately, and let soak for ten minutes.
  - d. Rinse off the filter media (flowing from the **clean** side to the dirty side), with low-pressure tap water.
  - e. After rinsing, shake off all excess water, and let the filter media air dry. DO NOT use compressed air or a heat gun to speed drying.
  - f. After the filter media is **completely** dry, EITHER carefully use a squeeze bottle to deposit air filter oil along each pleat, once only, OR spray oil along each pleat, once only, holding the spray nozzle away from the media approximately:  
Distance: 76 mm (3 in)
  - g. **Let the oil absorb into the filter media for 20 minutes before proceeding.** After 20 minutes, inspect the filter media. Carefully apply oil to any remaining visible white spots on the filter media. Allow oil to absorb.
4. Install air filter element with clamp onto the intake tube until it is fully seated into the groove. Tighten the clamp around the filter element flange.  
Torque: 6.2–6.8 N·m (45–55 **in-lbs**) Band clamp

## SERVICE PARTS

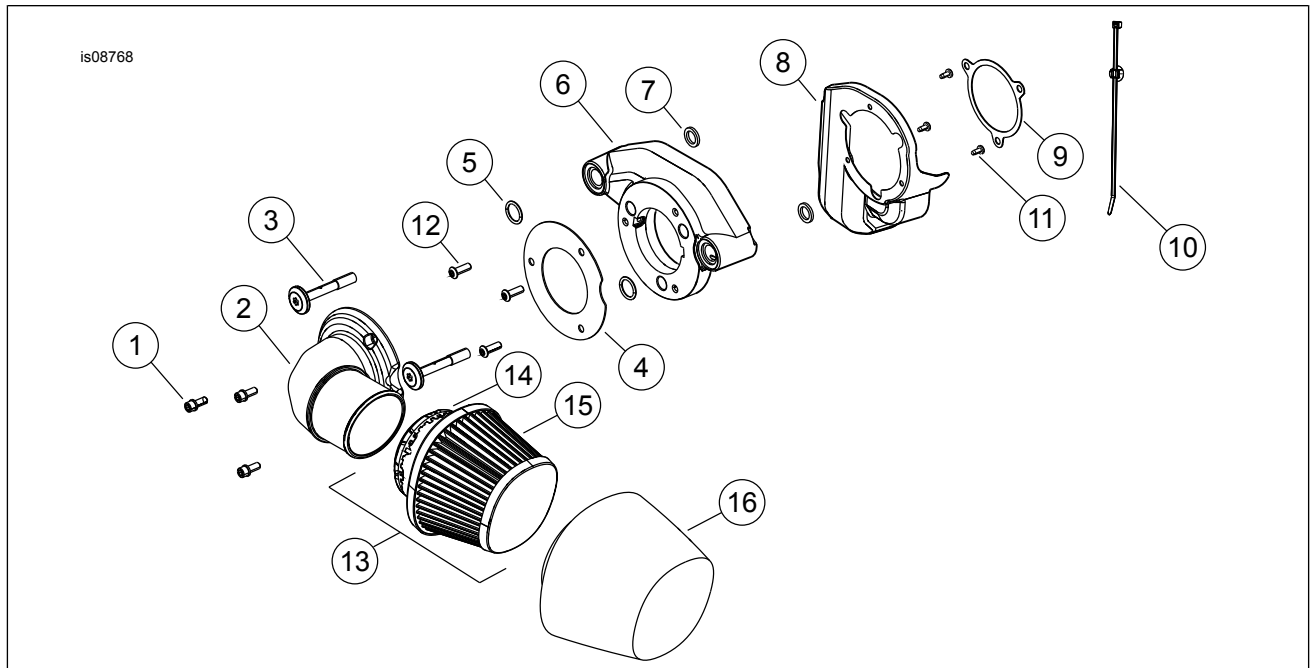

Figure 2. Service Parts: Screamin' Eagle Performance Air Cleaner Kit

Table 1. Service Parts

Item	Description (Quantity)	Part Number
1	Screw (3)	10500094
2	Intake tube, chrome	29000194
	Intake tube, black	29000193
3	Breather screw (2)	29400283
4	Gasket	29000178
5	O-ring (2)	11900040
6	Backplate, machined, chrome	Not sold separately
	Backplate, machined, black	Not sold separately
7	Square ring (2)	11900042
8	Throttle body cover	61300616
9	Gasket, backplate	29000149
10	Cable strap, two piece	12500015
11	Screw, self tapping (3)	68042-99
12	Screw, button head (3)	923
13	Air cleaner filter kit (chrome trim), includes items 14-15	29400275
	Air cleaner filter kit (black trim), includes items 14-15	29400276
14	Cover, band clamp	Not sold separately
15	Filter element	Not sold separately
16	Rain sock, air filter	29400318