



INSTRUCTIONS

-J04511

REV. 2007-10-29

SCREAMIN' EAGLE STAGE 2 BIG BORE KITS FOR EFI MODELS

GENERAL

Kit Number

27543-08, 27545-08, 27557-08, 27558-08. These kits are legal on California pollution controlled vehicles only.

Models

These kits are designed for installation on 2008 Touring, 2008 Dyna and 2008 Softail model motorcycles.

Table 1. Screamin' Eagle Big Bore EFI 1690 Stage 2 Kits

Description (Quantity)	Part Number
TOURING LEGAL, BLACK	27557-08
TOURING LEGAL, SILVER	27558-08
SOFTAIL LEGAL, BLACK	27543-08
DYNA LEGAL, BLACK	27545-08

Additional Parts Required

Installation of the camshafts included in this kit requires the separate purchase of spacers from a Harley-Davidson Dealer. Please refer to the parts catalog for the correct part number for the spacer needed.

NOTE

This instruction sheet references Service Manual information. A Service Manual for your model motorcycle is required for this installation and is available from a Harley-Davidson Dealer.

CAUTION

You must recalibrate the ECM when installing this kit. Failure to properly recalibrate the ECM can result in severe engine damage. (00399b)

WARNING

The rider's safety depends upon the correct installation of this kit. Use the appropriate service manual procedures. If the procedure is not within your capabilities or you do not have the correct tools, have a Harley-Davidson dealer perform the installation. Improper installation of this kit could result in death or serious injury. (00333a)

WARNING

To prevent accidental vehicle start-up, which could cause death or serious injury, disconnect battery cables (negative (-) cable first) before proceeding. (00307a)

WARNING

Disconnect negative (-) battery cable first. If positive (+) cable should contact ground with negative (-) cable connected, the resulting sparks can cause a battery explosion, which could result in death or serious injury. (00049a)

WARNING

When servicing the fuel system, do not smoke or allow open flame or sparks in the vicinity. Gasoline is extremely flammable and highly explosive, which could result in death or serious injury. (00330a)

Kit Contents

See Figure 2, Figure 3, and Table 2, Table 3, .

INSTALLATION

Installation of this kit is divided into five steps:

1. Big Bore Cylinder and Piston Conversion
2. High Performance Camshafts
3. High Performance Clutch Diaphragm Spring
4. High Performance Air Cleaner
5. Calibrate the ECM

NOTES

This Big-Bore Stage 2 kit is intended for High Performance applications only. Engine-related performance parts are intended for the experienced rider only.

The air cleaner contained in these kits is designed to perform with these kits only. Any other combination of components is not confirmed to be legal for street use.

Gaskets provided in the 1690 conversion kit eliminate the need for original head gasket O-rings. For this reason, DO NOT install the Original Equipment (OE) O-rings (Part Number 11273) to the top of cylinder dowels, or severe engine damage may occur.

Big-Bore Cylinder and Piston Conversion

NOTE

Installation of this kit requires removal of the cylinder heads, cylinders and pistons. Refer to Section 3, ENGINE: STRIPPING MOTORCYCLE FOR SERVICE and TOP END OVERHAUL of the applicable Service Manual for instructions.

High Performance Camshafts

NOTE

Installation of this kit requires removal and re-installation of the cam support plate. Refer to Section 3, ENGINE: BOTTOM END Cam Support Plate, Removal and Disassembly/Assembly

(Camshaft, Camshaft Bearings) of the applicable Service Manual for instructions.

Measuring Piston-to-Valve Clearance

After installing non-stock cams, check piston-to-valve clearance.

1. Apply 1/8-inch (3 mm) layer of clay to crowns of pistons in areas where valves meet pistons.
2. Refer to the appropriate Service Manual and assemble the heads and valve train, and tighten cylinder studs to torque specified.
3. Turn engine through two complete revolutions by hand.
4. Remove heads and measure clay at its thinnest point.

NOTE

Clay must measure 0.080 inch (2.03 mm) at its thinnest point. If this measurement does not meet minimum thickness, depth of valve notches must be increased. The depth of the notches must not exceed 0.135 inch (3.43 mm).

Measuring Valve-to-Valve Clearance

NOTE

Wait ten minutes before turning the engine after installing push rods. This allows tappets to bleed down and prevents you from bending push rods or valves.

1. Rotate the engine so that both valves of the front cylinder are partially open. Shine a light through the exhaust port and look through the spark plug hole to view the valves. Turn engine, if required, to the point where the exhaust and intake valve heads cross, where both valves are off their seats by an equal amount.

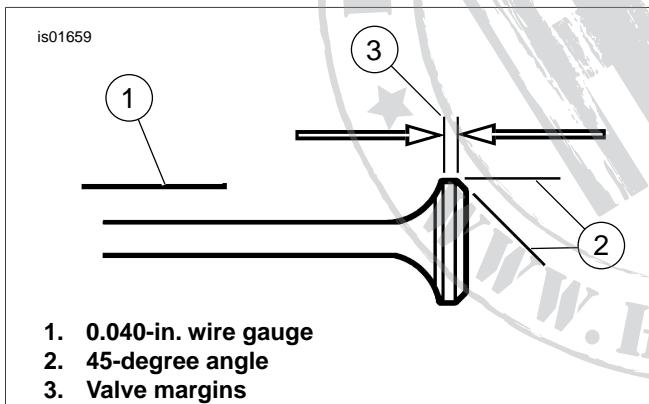

Figure 1. Beveling Valve Heads

NOTE

See Figure 1. If it is necessary after inspection to grind the intake and exhaust valves in order to meet the 0.040-inch (1.016 mm) clearance between the two valve heads, the margins (3) must be measured as follows: 0.031-inch (0.787 mm) minimum margin on exhaust valves and 0.015-inch (0.381 mm) minimum margin on intake valves.

2. A 0.040-inch (1.016 mm) clearance is required between the two valve heads. Use a 0.040-inch wire gauge (1) to measure this. To adjust the clearance, grind the edges of the intake and exhaust valves at a 45-degree angle (2).
3. Repeat steps 1 and 2 for the rear cylinder.

Install New Pistons, Cylinders, and Cylinder Heads

1. **Assembly** - Refer to the ENGINE section of the appropriate Service Manual for installing pistons, cylinders and cylinder heads.

High Performance Clutch Diaphragm Spring

1. **Disassembly** - Refer to the DRIVE section of the appropriate Service Manual to remove primary chain case, chain, diaphragm spring retainer and diaphragm spring.
2. **Assembly** - Refer to the DRIVE section of the appropriate Service Manual for installing diaphragm spring retainer, diaphragm spring, chain and primary chain case.

High Performance Air Cleaner

Follow the instructions included with the High Performance air cleaner in this kit for installation.

Calibrate the ECM

Have dealer recalibrate the ECM prior to starting vehicle.

Final Assembly

WARNING

Connect positive (+) battery cable first. If positive (+) cable should contact ground with negative (-) cable connected, the resulting sparks can cause a battery explosion, which could result in death or serious injury. (00068a)

WARNING

After installing seat, pull upward on seat to be sure it is locked in position. While riding, a loose seat can shift causing loss of control, which could result in death or serious injury. (00070b)

1. Connect the battery cables, positive (+) cable first.
2. Refer to the Service Manual, and follow instructions to install the seat.

SERVICE PARTS

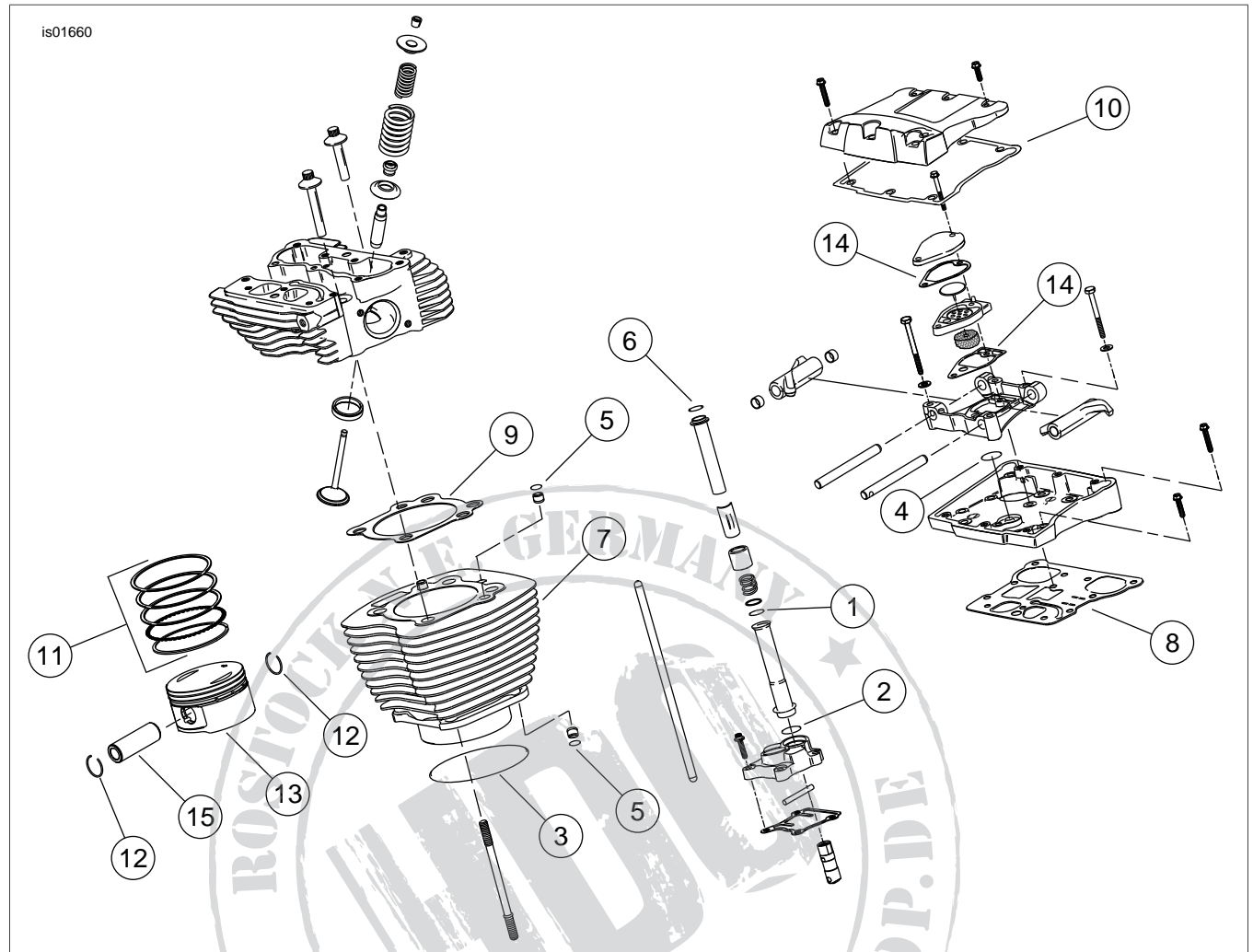

Figure 2. Service Parts: Screamin' Big-Bore EFI Stage 2 Kit

Table 2. Service Parts: Screamin' Eagle Big Bore EFI Stage 2 Kit

Item	Description (Quantity)	Part Number	Item	Description (Quantity)	Part Number
1	O-ring, middle push rod cover (4)	11132A	11	Ring set, piston, 1690 standard (2)	21918-99
2	O-ring, lower push rod cover (4)	11145A	12	Lock wire, piston pin (4)	22097-99
3	O-ring, cylinder spigot (2)	11256	13	Kit, Piston, 1690 standard (2)	21989-07
4	O-ring, rocker arm support (2)	11270	14	Kit, breather gasket	17162-03
5	O-ring, cylinder deck ring dowel (2)	11273	15	Pin, piston (2)	22131-05
6	O-ring, upper push rod cover (4)	11293		Kit, exhaust gasket (not shown)	17048-98
7	Assembly, 1690 cylinder, black (2) Assembly, 1690 cylinder, silver (2)	16547-99 16548-99		Seal, intake manifold (not shown) (2)	26995-86B
8	Gasket, rocker cover base (2)	16719-99A		Stage 1 Air cleaner (not shown) Dyna Touring Softail	Kits 29406-08 29260-08 29773-02C
9	Kit, head gasket (2)	16787-99A		Clutch diaphragm spring, high performance (not shown)	37951-98
10	Gasket, rocker cover top (2)	17386-99A		Loctite 262, red, 0.5 ml tube (not shown)	94673-99

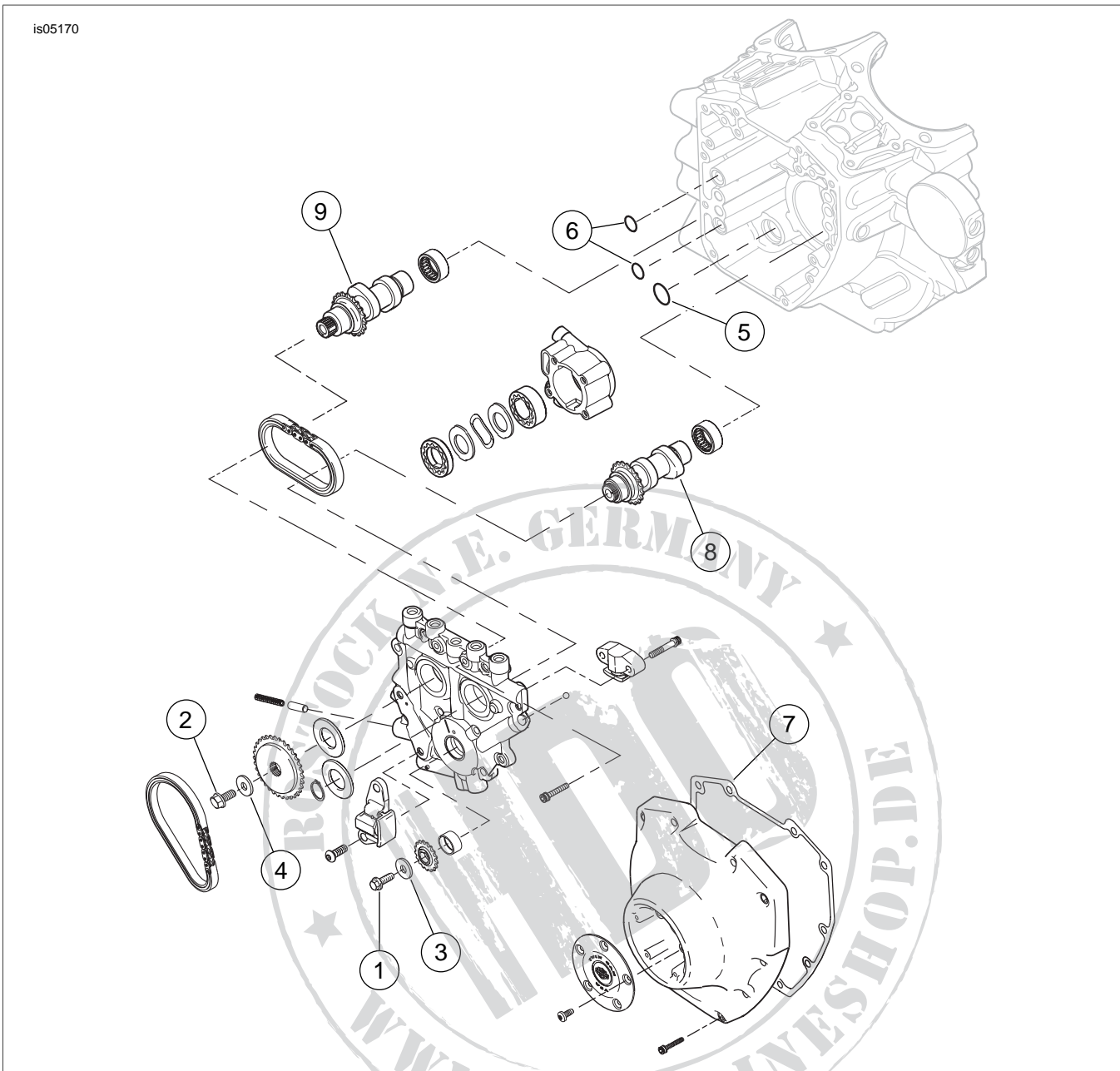

Figure 3. Service Parts: Screamin' Eagle Big Bore EFI Stage 2 Kit

Table 3. Service Parts: Screamin' Eagle Big-Bore EFI Stage 2 Kit

Item	Description (Quantity)	Part Number	Item	Description (Quantity)	Part Number
1	Capscrew, flanged (crank)	898A	6	O-ring, cam plate-to-crankcase (2)	11301
2	Capscrew, flanged (cam)	996	7	Gasket, cam cover	25244-99A
3	Washer (crank)	6278A	8	Camshaft, front, SE255	25417-07
4	Washer (cam)	6294	9	Camshaft, rear, SE255	25427-07
5	O-ring, oil pump-to-cam plate	11286			