



INSTRUCTIONS

-J05906

2015-02-25

LEFT SIDE MEDALLION (ALTERNATOR ACCESS COVER) KITS

GENERAL

Kit Number

25700307 , 25700308 , 25700309 , 25700460

Models

For model fitment information, see the P&A retail catalog or the Parts and Accessories section of www.harley-davidson.com (English only).

Kit Contents

This kit contains one left side medallion (not serviced), one O-ring (Part No. 11900029) and these instructions.

REMOVAL

▲ WARNING

To prevent accidental vehicle start-up, which could cause death or serious injury, remove main fuse before proceeding. (00251b)

1. See the owner's manual. Remove main fuse.
2. See Figure 1. Remove two screws (4). Retain for installation.
3. Remove alternator access cover (3).
4. Remove and discard O-ring (2).

INSTALLATION

1. Install **new** O-ring (2) on the **new** left side medallion.
2. Secure the medallion with screws (4) removed earlier. Tighten to 10–12 N·m (89–106 **in-lbs**)
3. See the owner's manual. Install main fuse.

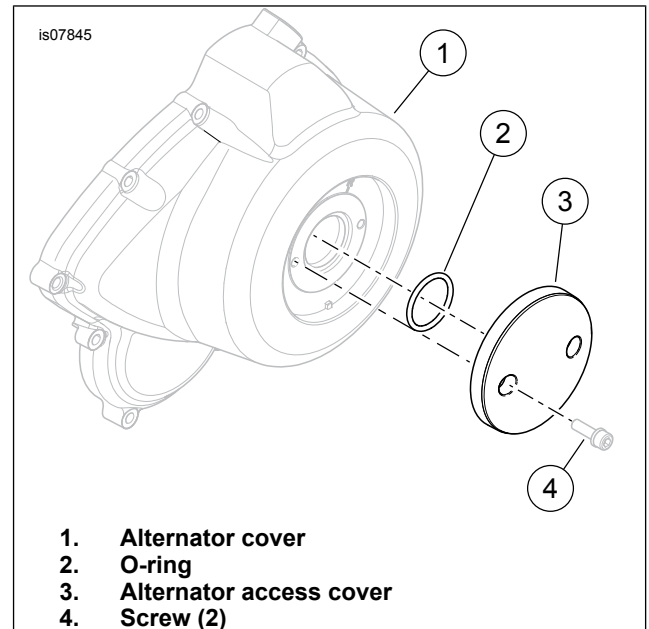

Figure 1. Alternator Access Cover

