



INSTRUCTIONS

-J03646

REV. 2006-04-19

DERBY COVER KIT

GENERAL

Kit Number

25441-04A, 25338-99A, 25340-99A, 25372-02A, 25334-99A, 25713-99A, 25335-99A, 25336-06, 25347-02A

Models

These kits are designed for installation on all 1999 and later 1340 Evolution and Twin Cam equipped models.

Additional Parts Required

NOTE

Harley-Davidson recommends that the clutch inspection cover gasket, Part Number 25416-99C (sold separately), be replaced when installing this kit. This gasket is available from any Harley-Davidson dealer.

NOTE

A Service Manual for your model motorcycle is available from a Harley-Davidson Dealer.

Kit Contents

See Figure 2 and Table 1.

INSTALLATION

For models equipped with left side exhaust pipe:

WARNING

Perform this installation when the engine is cool. Working on or near the exhaust system when the engine is hot could result in severe burns. (00311a)

NOTE

Remove clutch inspection (derby) cover with motorcycle upright, not on side stand. If cover is removed with motorcycle on side stand, primary fluid will leak out of primary chaincase.

1. On models so equipped, remove the **left-side** passenger footboard. Using a T27 TORX® drive head, remove the derby cover from the primary chaincase. Discard the derby cover and fasteners.

NOTE

The gasket between the clutch inspection cover and the chaincase cover must be removed and all oil must be wiped from the gasket and groove in chaincase cover each time the cover is removed.

2. Remove the gasket from the groove in the chaincase cover and mounting surface.
3. Inspect gasket for tears or damage. Replace as required with gasket 25416-99C (sold separately).

NOTE

If installing the Derby cover on a 2006 and later Dyna, 2007 Softail, or 2007 Touring model, the original equipment gasket **must** be discarded and replaced with Derby Cover Gasket 25416-99C (sold separately).

4. To avoid punching holes in the clutch inspection cover gasket or enlarging the existing holes, install the new derby cover and gasket as follows:
 - a. Align the triangular shaped hole in the gasket with the top hole in the derby cover. Be sure the rubber molding and the words "towards clutch" face the motorcycle.
 - b. See Figure 2. Place a washer (2) from the kit onto the threads of one of the **new** screws (3). Insert the screw threads through the top hole in the derby cover, and carefully thread it all the way through the triangular shaped hole in the gasket. Do not push the screw through the hole.
 - c. Hang the derby cover on the primary chaincase cover flange by starting the top cover screw.
 - d. Start the remaining four screws and washers.
5. Install gasket (part number 25416-99C) and derby cover (1) on primary chaincase cover using screws and washers from the kit. Tighten screws to 84-108 **in-lbs** (10-12 Nm) in the sequence shown in Figure 1.

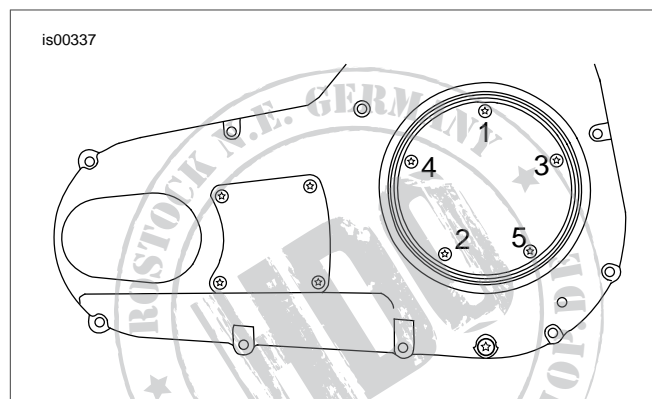

Figure 1. Torque Sequence, Clutch Inspection Cover

SERVICE PARTS

is00592

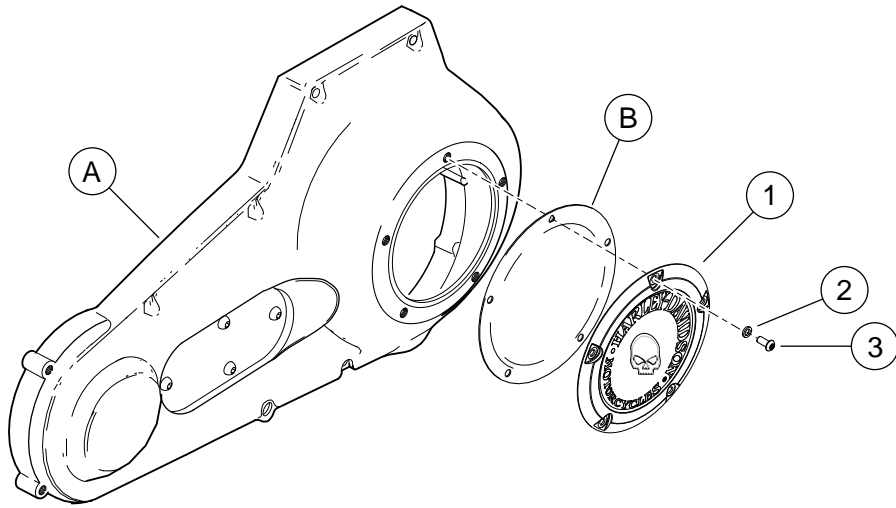

Figure 2. Service Parts: Derby Cover Kit

Table 1. Service Parts Table

Item	Description (Quantity)	Part Number
1	Derby cover	Not Sold Separately
2	Washer, 1/4 in. stainless steel (5)	9600
3	Screw, Torx, chrome (5)	9461
Items not included in kit:		
A	Original equipment primary chaincase cover	
B	Clutch inspection cover gasket, part number 25416-99C	

