



# INSTRUCTIONS

-J03654

REV. 2005-09-23

## DERBY COVER KIT

### GENERAL

#### Kit Number

25125-04A, 25127-04A, 25130-04A, 25343-04A, 25383-04A, 25384-04A, 25440-04A

#### Models

These kits are designed to fit 2004 and later XL model motorcycles.

#### Kit Contents

See Figure 1 and Table 1.

### INSTALLATION

#### NOTE

On models without forward controls, it may be necessary to remove the left footpeg for removal and assembly of the derby cover.

1. See Figure 1. Remove and discard the existing screws and washers that secure the clutch inspection cover. Remove and discard the original cover.
2. Place new cover (1) in position and secure with the washers (3) and screws (2) from kit. Tighten screws in a crosswise pattern to 84-108 **in-lbs** (9.5-12.2 Nm).

### SPECIAL CARE INSTRUCTIONS

This Sportster Derby Cover is chrome plated, with paint filled accents.

#### NOTE

To prevent damage to the cover surface, do not use any detergents, chemical solvents, polishes or abrasive cleaning agents.

To keep this surface in best condition, lightly wipe with a Harley-Davidson Micro Fiber cloth, Part Number 94663-02, using clear water or a mild Harley-Davidson cleaner such as:

- Sunwash (Part Number 94659-98)
- Bug Remover (Part Number 94657-98)
- Harley Gloss (Part Number 94627-98).

#### NOTE

These cleaners are available separately or as part of the Harley Care Starter Kit, Part Number 94671-99A from your Harley Davidson Dealer.

### SERVICE PARTS

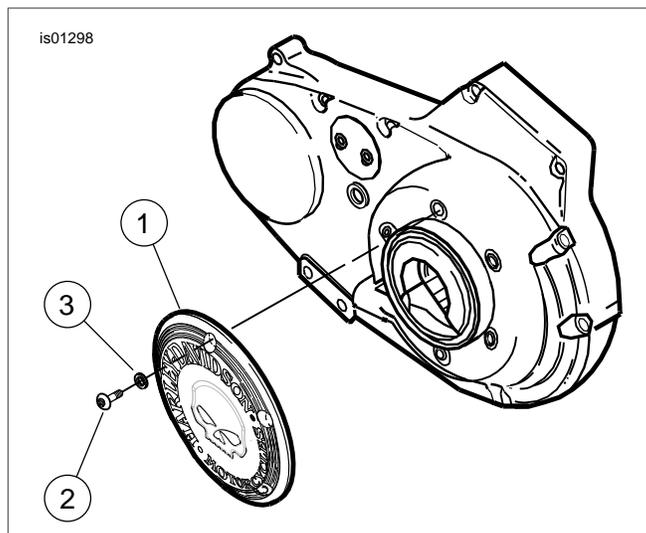

Figure 1. Service Parts: Derby Cover Kit

Table 1. Service Parts: Derby Cover Kit

Item	Description (Quantity)	Part Number
1	Derby cover	Not Sold Separately
2	Screws (6)	9461
3	Washers (6)	9600

