



INSTRUCTIONS

-J05470

2012-04-17

SCREAMIN' EAGLE TWIN CAM 4.625" STROKE FLYWHEEL KIT

GENERAL

Kit Numbers

24100007, 24100011

Models

For model fitment information, see the P&A Retail Catalog or the Parts and Accessories section of www.harley-davidson.com (English only).

Kit Contents

Table 1. Kit Contents

Description (Quantity)	Part Number
Flywheel assembly (1)	Not Sold Separately

Additional Parts Required

NOTE

On 2003 - Later Models: SE Lefty Bearing Kit (P/N 24004-03B) must be used on the primary side of flywheel. Follow instructions included with bearing assembly.

NOTE

If the SE crankcase is used, the lefty main bearing is already installed. However, an additional thrust washer (Part Number 8972) will be required.

Table 2. Additional Parts Required

Description (Quantity)	Part Number
4.060" Bore Cylinders	See Catalog
4.060"/4.625" Bore/Stroke Pistons	See Catalog
Engine overhaul gasket kit	See your Dealer
SE Lower Piston Cooling Jet	See Catalog
SE Lefty Bearing Kit (See Note, above)	24004-03B

▲ WARNING

The rider's safety depends upon the correct installation of this kit. Use the appropriate service manual procedures. If the procedure is not within your capabilities or you do not have the correct tools, have a Harley-Davidson dealer perform the installation. Improper installation of this kit could result in death or serious injury. (00333a)

NOTE

This instruction sheet references service manual information. A service manual for your model motorcycle is required for this installation and is available from a Harley-Davidson Dealer.

NOTE

Harley-Davidson motorcycles equipped with some Screamin' Eagle® high-performance parts may not be used on public roads and in some cases must be restricted to closed course competition. This engine related performance part is intended

for racing applications and is not legal for sale or use in California on pollution controlled motor vehicles.

▲ WARNING

When servicing the fuel system, do not smoke or allow open flame or sparks in the vicinity. Gasoline is extremely flammable and highly explosive, which could result in death or serious injury. (00330a)

INSTALLATION

▲ WARNING

Disconnect negative (-) battery cable first. If positive (+) cable should contact ground with negative (-) cable connected, the resulting sparks can cause a battery explosion, which could result in death or serious injury. (00049a)

1. Disconnect the battery, negative cable first.
2. Follow instructions in applicable service manual and remove engine from chassis.
3. Refer to the ENGINE section in the service manual and follow steps to disassemble engine and remove crankshaft.

NOTE

The inner bearing race and one thrust washer will be discarded from the SE Lefty Bearing Kit (See Figure 1), since the new flywheel comes with a race and thrust washer installed.

For 2002 and earlier models or models with Timkin® tapered roller bearing conversion, see **Thrust Washer and Inner Bearing Race Removal** and remove the inner bearing race (30) and thrust washer (2) race from flywheel (see Figure 1).

4. **Stock Crankcases:** For 2003 - Later models, refer to the service manual for removal and installation of the main bearing in the left crankcase half from the SE Left Bearing Kit. **SE Crankcases:** Use thrust washer (4), Part Number 8972 purchased separately when installing flywheel in crankcase.

NOTE

The inner bearing race and on thrust washer will be discarded from the SE Lefty Bearing Kit (see Figure 1), since the new flywheel comes with a race and thrust washer installed.

For 2002 and earlier models or models with Timken tapered roller bearing conversion, see **Thrust Washer and Inner Bearing Race Removal** and remove the inner bearing race (30 and thrust washer (2) race from flywheel (see Figure 1).

5. Refer to service manual, BOTTOM END OVERHAUL: ASSEMBLY and follow steps for assembling engine with the new crankshaft.
6. Follow instructions in applicable service manual and install engine in chassis.

-J05470

Many Harley-Davidson® Parts & Accessories are made of plastics and metals which can be recycled. Please dispose of materials responsibly.

1 / 4

is02882a

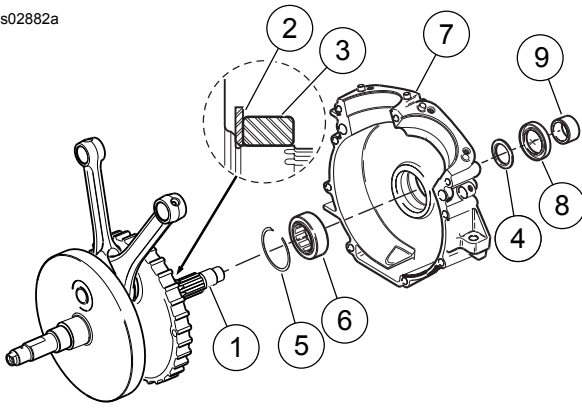

1. Flywheel assembly (includes items 2 and 3)
2. Thrust washer (included with flywheel)
3. Bearing inner race (included with flywheel)
4. Thrust washer (from Lefty Bearing Kit or purchased separately)
5. Lock Ring (from Lefty Bearing Kit)
6. Straight roller bearing (from Lefty Bearing Kit)
7. Crankcase (left side shown) (save existing parts)
8. Seal (purchased separately)
9. Spacer (save existing part)

Figure 1. Bearing and Thrust Washer Installation

OPERATION

1. Refer to BREAK-IN RIDING RULES in the owner's manual for instructions to break-in the new engine.

Thrust Washer and Inner Bearing Race Removal

1. Obtain FLYWHEEL SUPPORT FIXTURE (HD-44358), see Figure 2. Install brass jaws or shop towels around the teeth of a vise to prevent tool damage. Clamp the tool in the vise with the round hole topside.
2. Insert the right-side crankshaft end through the hole, resting the flywheel assembly on the fixture. Slide the knurled locating pin down the slot in the tool to engage the crank pin hole. Hand tighten the locating pin.

is02883

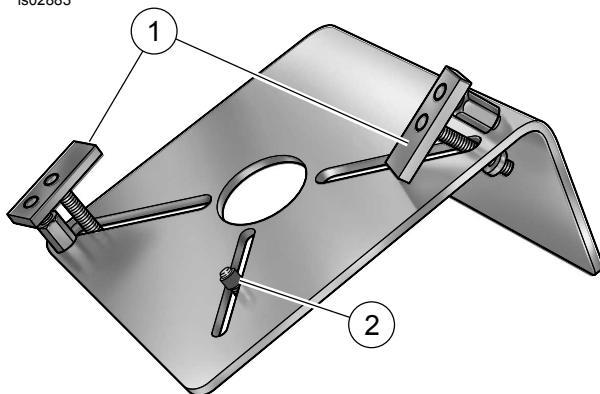

1. Hold down clamp (2)
2. Locating pin

Figure 2. Flywheel Fixture (Part Number HD-44358)

NOTE

For proper clamping force, hold-down clamp must not be tilted. Rotate hex on outboard stud until clamp is level.

3. Slide the hold-down clamp down the slot to engage the inboard side of the right flywheel half, then hand tighten the knurled nut at the bottom to secure. Repeat this step to secure the hold-down clamp on the opposite side of the flywheel.
4. See Figure 2. Position the WEDGE ATTACHMENT (HD-95637-46A) on the inboard side of the thrust washer, and turn the hex nuts an equal number of turns to draw the halves of the wedge together.

NOTICE

Install wedge attachment only so far as necessary to ensure positive contact with bearing inner race. Installing tool with more contact than necessary will result in damage to the flywheel (00500b)

5. Obtain two 3/8-16 x 6-1/2 inch long bolts and flat washers. Install the flat washers on the bolts. Obtain the bridge, forcing screw and hardened plug from the MAINSHAFT BEARING INNER RACE PULLER/INSTALLER (HD-34902B).
6. Slide one bolt into the channel on each side of the bridge so that the flat washer is between the bridge and bolt head. Thread the bolts into the wedge attachment an equal number of turns.

NOTE

Failure to use hardened plug may result in damage to forcing screw and/or sprocket shaft.

7. Sparingly apply graphite lubricant to the threads of the forcing screw to prolong service life and verify smooth operation. Start the forcing screw into the center hole of the bridge.
8. Place the cupped side of the hardened plug against the end of the sprocket shaft. Thread the forcing screw into the bridge until the steel ball at the end of the screw makes firm contact with the hardened plug.

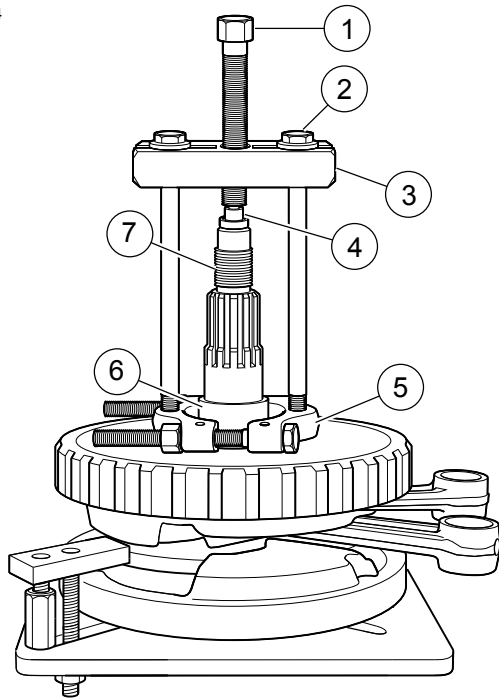

1. Forcing screw
2. 3/8-16 bolt
3. Bridge
4. Hardened plug
5. Wedge attachment
6. Bearing inner race
7. Sprocket shaft

Figure 3. Inner Race From Sprocket Removal

▲ WARNING

Be sure to follow manufacturer's instructions when using the Robinair Heat Gun or any other radiant heating device. Failure to follow manufacturer's instructions can cause a fire, which could result in death or serious injury. (00379a)

- Always keep hands away from tool tip area and heat shrink attachment.
- Be sure to turn the "ON/OFF" switch to the "OFF" position after use.

NOTE

To facilitate removal without heat, apply a light penetrating oil to shaft and leading edge of bearing inner race.

NOTE

Never use both heat and penetrating oil. Use only one or the other. Heat can cause the penetrating oil to ignite resulting in flames or fire.

9. Using the Robinair Heat Gun (HD-25070), uniformly heat the bearing inner race for about 30 seconds.
10. Turn the forcing screw until the thrust washer (and bearing inner race) moves approximately 1/8 inch (3.2 mm).
11. Turn the hex nuts an equal number of turns to separate the halves of the WEDGE ATTACHMENT.

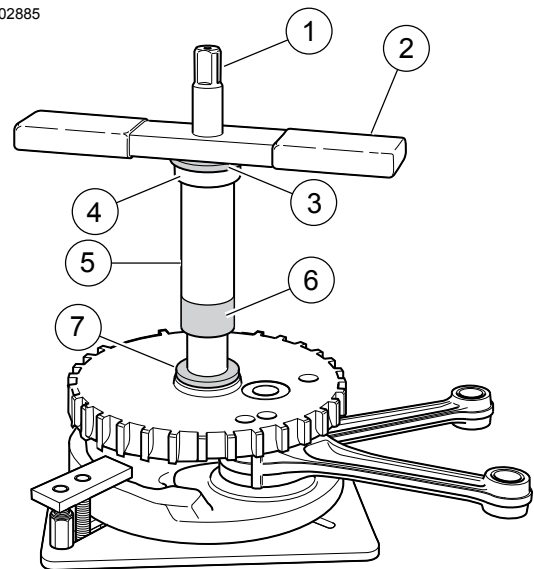

1. Pilot shaft
2. Handle
3. Flat washer
4. Thrust bearing
5. Sleeve
6. Inner race
7. Thrust washer

Figure 4. Thrust Washer and Bearing Inner Race Installation

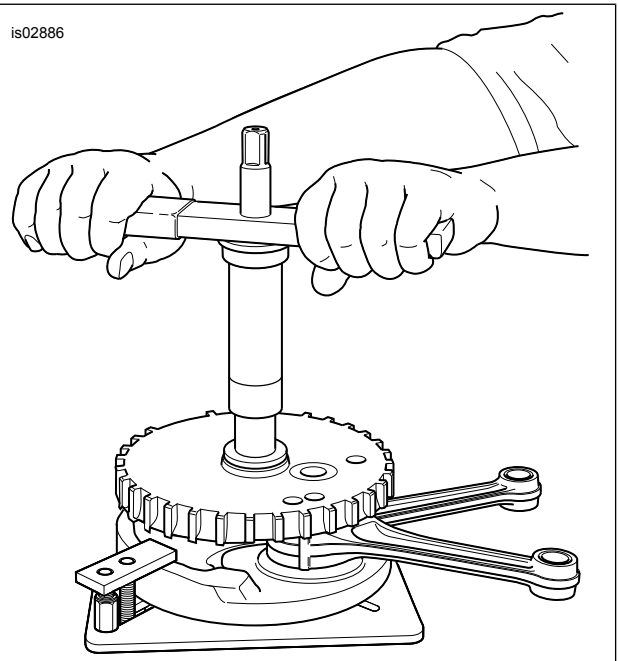

Figure 5. Inner Race onto Sprocket Installation

12. After bottoming the thrust washer on the shaft, reposition the WEDGE ATTACHMENT (HD-95637-46A) on the inboard side of the bearing inner race. Turn the hex nuts an equal number of turns to draw the halves of the wedge together.

NOTICE

Install wedge attachment only so far as necessary to ensure positive contact with bearing inner race. Installing tool with more contact than necessary will result in damage to the flywheel (00500b)

13. Verify that the tool assembly is square, so that the bearing inner race is not cocked during removal.

NOTE

To facilitate removal without heat, apply a light penetrating oil to shaft and leading edge of bearing inner race.

14. See Figure 3. Using the Robinair Heat Gun (HD-25070), uniformly heat the bearing inner race for about 30 seconds using a circular motion.
15. Turn the forcing screw until the bearing inner race is pulled free of the sprocket shaft.
16. Remove the thrust washer from the sprocket shaft.
17. Discard the bearing inner race and thrust washer.