



INSTRUCTIONS

-J01506

REV. 2006-04-10

CHROME LIFTER BLOCK COVER

GENERAL

Kit Number

18248-99, 18262-00, and 18278-06

Models

Table 1. Models

Kits	Models
18248-99	1999 to 2006 Touring and 1999 to 2005 Dyna models. This kit does not fit with Top Cover part numbers 66513-00 or 66505-00, Oil Hose Cover part number 37961-02 or Interface Cover part number 66530-03.
18262-00	2000 and later Softail models. This kit will not fit with Engine/Transmission Interface Top Cover part number 66510-00.
18278-06	2006 and later Dyna and 2007 Touring models.

Kit Contents

See below

Table 2. Kit Contents

Description (Quantity)	Part Number
Cover, lifter, front	Not Sold
Cover, lifter, rear	Not Sold
Cover, lifter, center	Not Sold
Bracket assembly (lifter cover, front)	Not Sold
Bracket assembly (lifter cover, rear)	Not Sold
Bracket assembly (lifter cover, center)	Not Sold
Screw, 8-32 x 1/2 in. (flat head hex) (2)	Not Sold
Screw, 1/4 -20 x 1/2 in. (hex socket cap) (3)	Not Sold*
Hex wrench (3/32 in.)	Not Sold
Hex wrench (3/16 in.)	Not Sold
Washer, 1/4 in. flat (2)	Not Sold

*For replacement part, use Harley Davidson part number 94310-91T. Apply Loctite 243 Threadlocker (blue) (Harley-Davidson part number 99642-97) to threads.

INSTALLATION

WARNING

The rider's safety depends upon the correct installation of this kit. Use the appropriate service manual procedures. If the procedure is not within your capabilities or you do not have the correct tools, have a Harley-Davidson dealer perform the installation. Improper installation of this kit could result in death or serious injury. (00333a)

NOTE

A Service Manual for your motorcycle is available at any Harley-Davidson Dealer.

NOTE

Removal of the air cleaner assembly and, in cases where the bike has forward controls, shifter linkage will aid in installation of this kit. Remove the air cleaner and, if necessary, shifter linkage by following procedures in the appropriate Service Manual.

1. Remove the two rear most screws on the rear lifter cover.
2. See Figure 1. Install rear lifter cover bracket (1) assembly using screws (2) removed in step 1. Torque screws to 90-120 in-lbs (10.0 - 13.5 Nm).
3. Remove the two screws most forward on the front lifter cover.
4. See Figure 2. Install front lifter cover bracket (1) assembly using screws (2) removed in step 3. Torque screws to 90-120 in-lbs (10.0 - 13.5 Nm).

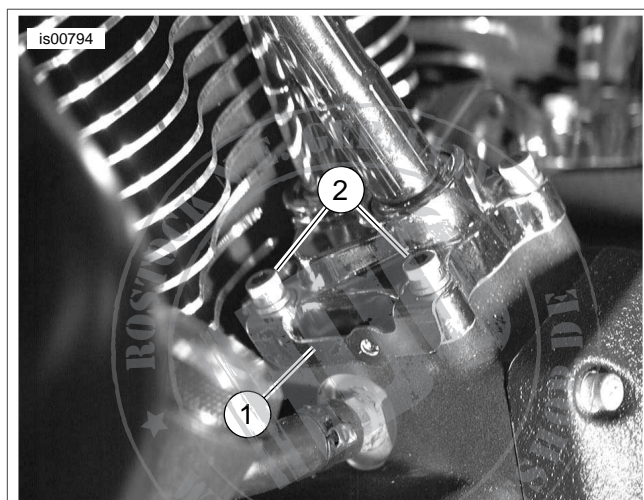

1. Rear lifter cover bracket
2. Rear lifter cover screws

Figure 1. Rear Lifter Cover Bracket Installed

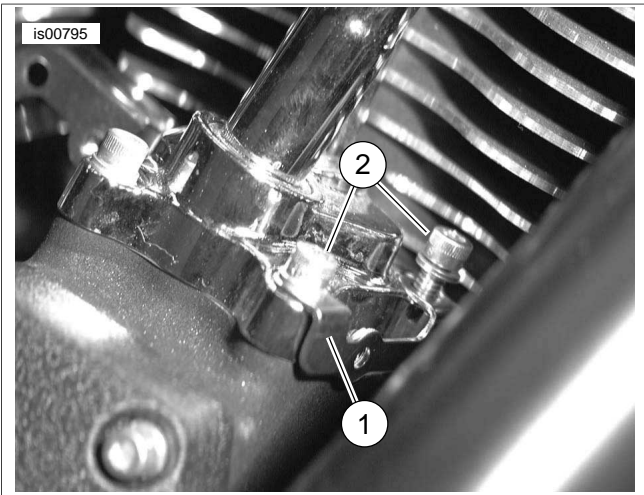

1. Front lifter cover bracket
2. Screws (2)

Figure 2. Front Lifter Cover Bracket Installed

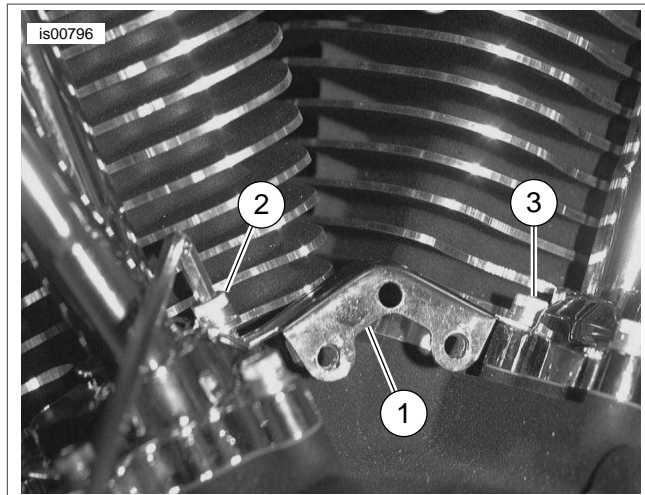

1. Center lifter cover bracket
2. Rear, inside screw
3. Front, inside screw

Figure 3. Center Lifter Cover Bracket Installation

5. Remove the front, inside screw on the rear lifter cover.
6. Remove the rear, inside screw on the front lifter cover.
7. See Figure 3. Install center lifter cover bracket (1) assembly using screws (2, 3) removed in steps 5 and 6. Torque screws to 90-120 **in-lbs** (10.0 - 13.5 Nm).
8. See Figure 4. Loosely install the front cover (1) using a 8-32 x 1/2 in. screw (2) (3/32 in. wrench provided) and a 1/4-20 x 1/2 in. screw (3) with washer (4).
9. Loosely install the rear cover using a 8-32 x 1/2 in. screw (3/32 in. wrench provided) and a 1/4-20 x 1/2 in. screw with washer.

NOTE

See Figure 5. Covers should encompass the push rod tubes and should rest on top of the case.

10. Position center lifter cover and check for alignment with relation to the front and rear lifter covers.
11. See Figure 6. Adjust front and rear tappet covers and tighten screws (2).
12. Install center tappet cover using 1/4-20 x 1/2 in. screw (2). Install screw from left side of engine using the 3/16 in. wrench provided in kit. See Figure 6. Pass the screw under the lowest set of cylinder fins and through to the bracket on the opposite side. Insure that the center cover threaded boss is flush and aligned with the mounting bracket to avoid cross threading.

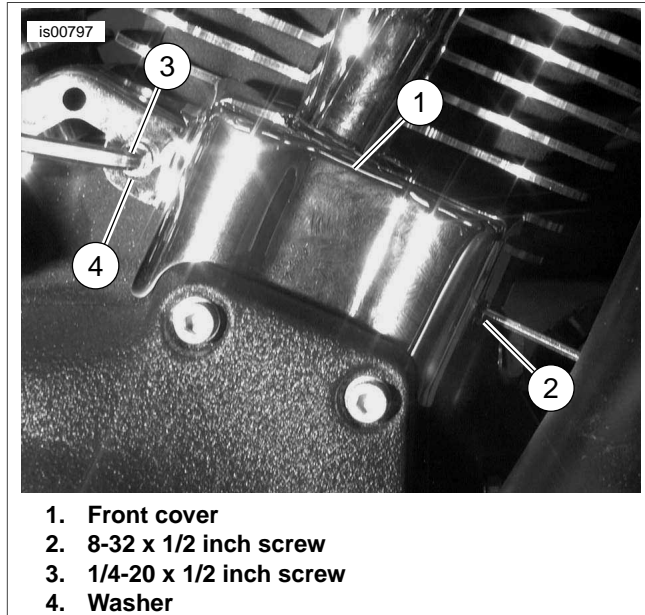

1. Front cover
2. 8-32 x 1/2 inch screw
3. 1/4-20 x 1/2 inch screw
4. Washer

Figure 4. Installing Front Lifter Cover to Brackets



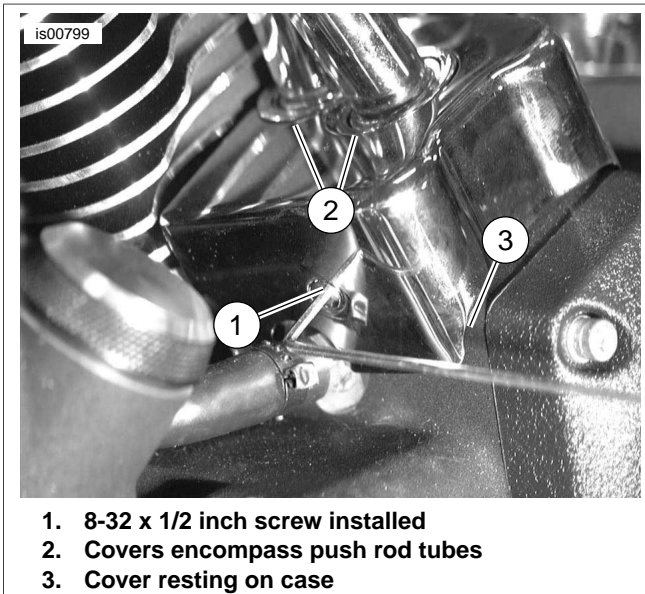

Figure 5. Cover in Correct Position

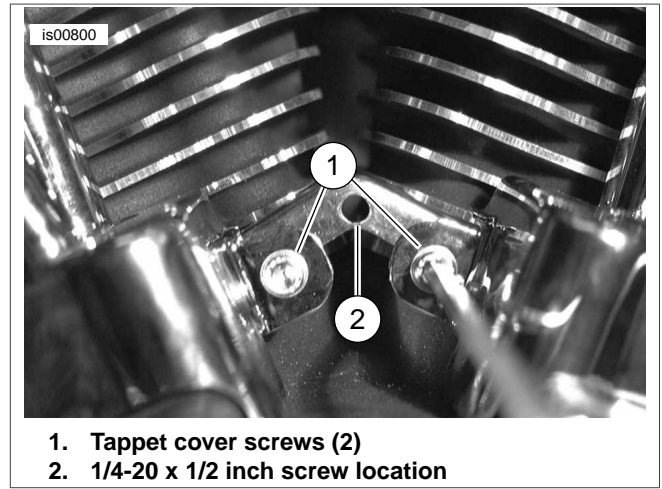

Figure 6. Lifter Cover Adjustment and Center Lifter Cover Screw Location

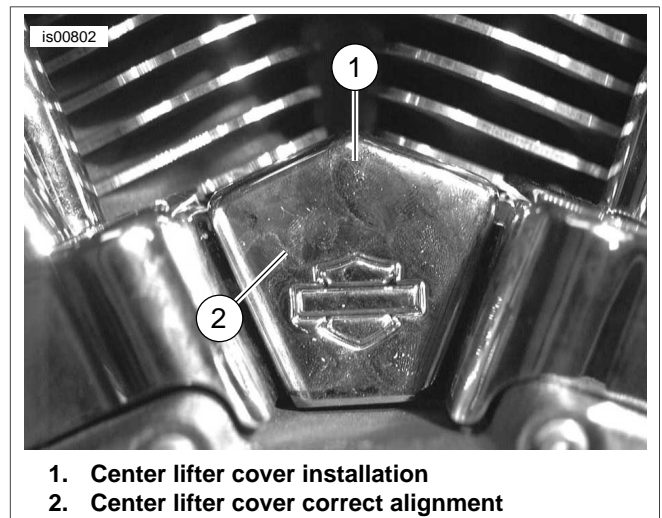

Figure 7. Center Lifter Cover Installed

