



INSTRUCTIONS

-J03548

REV. 2006-08-18

SCREAMIN' EAGLE VALVE SPRING KIT

GENERAL

Kit Number

18013-03A

Models

For model fitment information, please see the P&A Retail Catalog or the Parts and Accessories section of www.harley-davidson.com (English only).

Additional Parts Required

Additional parts may be required to replace or repair cylinder head components that are out of specification in order to assemble the cylinder heads and return them to service.

WARNING

The rider's safety depends upon the correct installation of this kit. If the procedure is not within your capabilities or you do not have the correct tools, have a Harley-Davidson dealer perform the installation. Improper installation of this kit could result in death or serious injury. (00308a)

NOTE

This kit is intended for use with high lift, high RPM applications. This kit will work with lifts up to 0.575 inches and up to 6500 rpm.

NOTE

This instruction sheet references Service Manual information. A Service Manual for your model motorcycle is required for this installation and is available from a Harley-Davidson Dealer.

Kit Contents

Table 1. Kit Contents

Description (Quantity)	Part Number
Collar, valve spring upper (4)	18015-03
Collar, valve spring lower with seal (4)	18016-03A
Key, valve spring collar (8)	18260-02
Valve spring (4)	18014-03

INSTALLATION

1. Refer to the Service Manual and follow the instructions under Stripping the Motorcycle for Top End Repair.
2. Follow the Service Manual instructions to remove the rocker covers and cylinder heads.

3. Using Valve Spring Compressor (HD-3436-B), compress the valve springs and remove upper collar keys, upper collar, and lower collar on all four valves.
4. If re-using the existing valves, use a fine tooth file to remove any burrs on the valve stem at the retainer groove. Mark the valve to ensure that it will be reassembled in the same head.

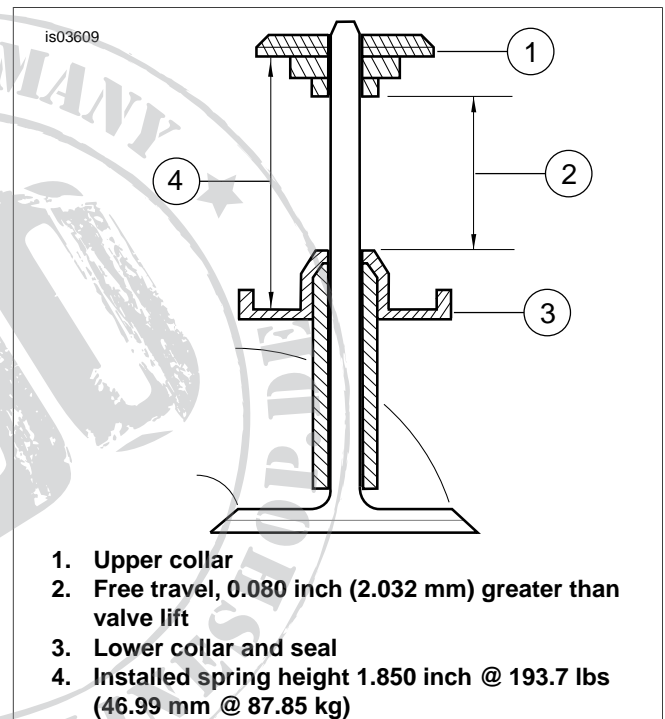

Figure 1. Installed Spring Height

5. Follow the Service Manual instructions under Cleaning and Inspection.
6. If any components are out of specification, follow the Service Manual instructions to replace and hone valve guides and to resurface the valve seats.
7. See Figure 1. Using the springs, collars and keys from this kit, assemble cylinder heads following Service Manual instructions.
8. Follow instructions in Service Manual to install the cylinder heads and rocker covers.
9. To return the motorcycle to service, follow the Service Manual instructions under Assembling Motorcycle After Top End Repair.