



# INSTRUCTIONS

-J05046

REV. 2009-10-26

## CHROME FRONT ENGINE MOUNT BRACKET

### GENERAL

#### Kit Number

16205-10

#### Models

For model fitment information, see the P&A Retail Catalog or the Parts and Accessories section of [www.harley-davidson.com](http://www.harley-davidson.com) (English only).

#### Additional Parts Required

Loctite® 272 (98618-03)

### WARNING

The rider's safety depends upon the correct installation of this kit. Use the appropriate service manual procedures. If the procedure is not within your capabilities or you do not have the correct tools, have a Harley-Davidson dealer perform the installation. Improper installation of this kit could result in death or serious injury. (00333a)

#### Kit Contents

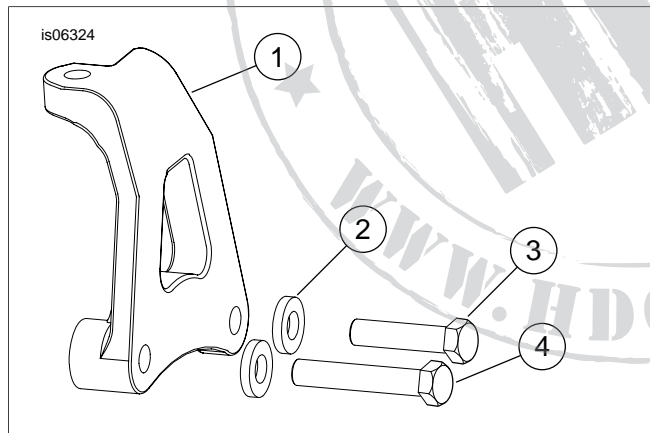

Figure 1. Service Parts: Chrome Front Engine Mount Bracket

Table 1. Service Parts

Item	Description (Quantity)	Part Number
1	Engine mounting bracket, chrome	Not Sold Separately
2	Washer (2)	6615
3	Screw, 1-1/2 x 3/8 inch	94236-91T
4	Screw, 2 inch	94238-91T

### NOTE

Kit 16213-10 contains a chrome stabilizer link and hardware to complement this kit.

### INSTALLATION

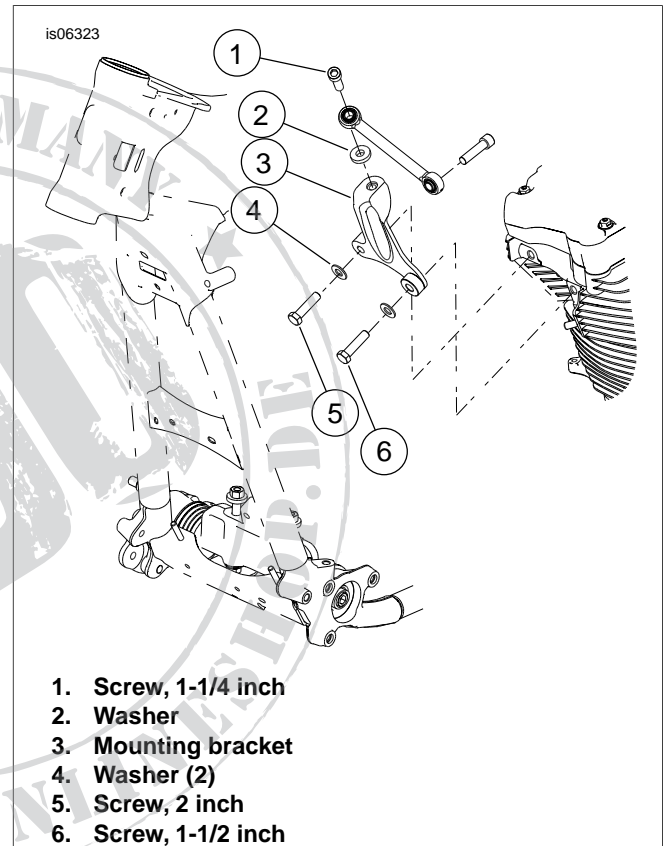

Figure 2. Remove Front Engine Mounting Bracket

1. See Figure 2. Remove the right side screw (1) and washer (2) from the front stabilizer link. Save the screw and washer for reuse.
2. Standing on the left side of the motorcycle, remove two hex head screws (5 and 6) and flat washers (4) to release the top engine mounting bracket (3) from the front cylinder head.
3. Apply a few drops of Loctite 272 to the new bolts in the kit and install the new engine mounting bracket with the long screw (5) and washer on the right side and the short screw (6) and washer on the left side of the bracket. Tighten bolts to 30-35 ft-lbs (40.6-47.4 Nm).
4. Apply a few drops of Loctite to the screw (1) and install the screw and washer (2) to the stabilizer link and engine mounting bracket and tighten to 18-22 ft-lbs (24.4-29.8 Nm).